

Circuitor

REACTIVE ENERGY REGULATOR

Computer SMART III



INSTRUCTION MANUAL

(M015B01-03-21A)



SAFETY PRECAUTIONS

Follow the warnings described in this manual with the symbols shown below.

	<p>DANGER Warns of a risk, which could result in personal injury or material damage.</p>
---	---

	<p>ATTENTION Indicates that special attention should be paid to a specific point.</p>
---	--

If you must handle the unit for its installation, start-up or maintenance, the following should be taken into consideration:

	<p>Incorrect handling or installation of the unit may result in injury to personnel as well as damage to the unit. In particular, handling with voltages applied may result in electric shock, which may cause death or serious injury to personnel. Defective installation or maintenance may also lead to the risk of fire.</p> <p>Read the manual carefully prior to connecting the unit. Follow all installation and maintenance instructions throughout the unit's working life. Pay special attention to the installation standards of the National Electrical Code.</p>
---	--

	<p>Refer to the instruction manual before using the unit</p> <p>In this manual, if the instructions marked with this symbol are not respected or carried out correctly, it can result in injury or damage to the unit and / or installations.</p>
---	--

CIRCUTOR, SA reserves the right to modify features or the product manual without prior notification.

DISCLAIMER

CIRCUTOR, SA reserves the right to make modifications to the device or the unit specifications set out in this instruction manual without prior notice.

CIRCUTOR, SA on its web site, supplies its customers with the latest versions of the device specifications and the most updated manuals.

www.circutor.com



	<p>CIRCUTOR, recommends using the original cables and accessories that are supplied with the device.</p>
---	--

CONTENTS

SAFETY PRECAUTIONS	3
DISCLAIMER	3
CONTENTS.....	4
REVISION LOG	6
SYMBOLS.....	6
1.- VERIFICATION UPON RECEPTION	7
2.- PRODUCT DESCRIPTION	7
3.- DEVICE INSTALLATION	9
3.1.- PRIOR RECOMMENDATIONS	9
3.2.- RECOMMENDATIONS FOR USING THE COMPUTER SMART III REGULATOR IN MEDIUM-VOLTAGE AUTOMATIC CAPACITOR BANKS.....	9
3.3.- INSTALLATION	10
3.4.- DEVICE TERMINALS.....	12
3.5.- CONNECTION DIAGRAM.....	13
3.5.1.- 3 VOLTAGES + NEUTRAL AND 3 CURRENTS, COMPUTER SMART III 6 MODEL	13
3.5.2.- 3 VOLTAGES + NEUTRAL AND 3 CURRENTS, COMPUTER SMART III 12 MODEL.....	14
3.5.3.- 3 VOLTAGES + NEUTRAL AND 3 CURRENTS, COMPUTER SMART III 14 MODEL.....	15
3.5.4.- 3 VOLTAGES + NEUTRAL AND 1 CURRENT, COMPUTER SMART III 6 MODEL	16
3.5.5.- 3 VOLTAGES + NEUTRAL AND 1 CURRENT, COMPUTER SMART III 12 MODEL.....	17
3.5.6.- 3 VOLTAGES + NEUTRAL AND 1 CURRENT, COMPUTER SMART III 14 MODEL.....	18
3.5.7.- 2 VOLTAGES AND 1 CURRENT, COMPUTER SMART III 6 MODEL.....	19
3.5.8.- 2 VOLTAGES AND 1 CURRENT, COMPUTER SMART III 12 MODEL.....	20
3.5.9.- 2 VOLTAGES AND 1 CURRENT, COMPUTER SMART III 14 MODEL.....	21
3.5.10.- LEAKAGE CURRENT CONNECTION, I _Δ	22
3.6.- STARTING UP THE DEVICE	23
4.- OPERATION	24
4.1.- DEFINITIONS.....	25
4.1.1. FOUR-QUADRANT REGULATOR	25
4.1.2. STAGES AND STEPS.....	25
4.1.3. FCP SYSTEM (FAST COMPUTERIZED PROGRAM)	25
4.1.4. REGULATION PROGRAM	25
4.1.5. PLUG AND PLAY.....	26
4.1.6. CONNECTION TIME (TON) AND RECLOSING TIME (TREC).....	26
4.1.7. THD AND HARMONICS.....	26
4.2.- MEASUREMENT PARAMETERS.....	27
4.2.1. Connection type: 3U.3C	27
4.2.2. Connection type: 3U. 1C	28
4.2.3. Connection type: 2U. 1C	29
4.3.- KEYBOARD FUNCTIONS.....	30
4.4.- DISPLAY	32
4.4.1. STATUS OF THE CAPACITORS	33
4.4.2. STATUS OF THE DEVICE	33
4.4.3. ANALOGUE BAR.....	34
4.4.4. OTHER SYMBOLS OF THE DISPLAY	34
4.5.- LED INDICATORS.....	35
4.6.- OPERATING STATES	36
4.6.1. MEASUREMENT STATUS	36
4.6.2. TEST STATUS	55
4.7.- INPUTS.....	58
4.8.- OUTPUTS.....	58
4.9.- COMMUNICATIONS	59
4.9.1. CONNECTIONS.....	59
4.9.2. PROTOCOL	60
4.9.3. MODBUS MEMORY MAP	61
4.9.4. EXAMPLE OF A MODBUS QUERY	70
5.- CONFIGURATION	71
5.1.- PLUG&PLAY	72
5.2.- CURRENT TRANSFORMATION RATIO.....	75
5.3.- TARGET COS φ.....	76

5.4.- CONNECTION AND RECLOSING TIME.....	77
5.5.- CONNECTION TYPE.....	78
5.6.- PHASE CONNECTION.....	78
5.7.- NO. OF STAGES.....	80
5.8.- PROGRAM.....	81
5.9.- C/K FACTOR.....	82
5.10.- VOLTAGE LEVEL.....	84
5.11.- EXPERT SETUP.....	85
5.12.- VOLTAGE TRANSFORMATION RATIO.....	86
5.13.- HYSTERESIS.....	87
5.14.- STATUS OF THE STAGES.....	88
5.15.- DISPLAY.....	89
5.16.- ANALOGUE BAR.....	90
5.17.- FAN.....	90
5.18.- UNDERVOLTAGE TRIP.....	91
5.19.- COMMUNICATIONS.....	93
5.20.- CLEAR.....	94
5.21.- ENABLING ALARMS.....	95
5.22.- VOLTAGE ALARMS.....	96
5.23.- COS ϕ LOW ALARM.....	97
5.24.- COS ϕ HIGH ALARM.....	98
5.25.- VOLTAGE THD ALARM.....	99
5.26.- CURRENT x I THD ALARM.....	100
5.27.- TEMPERATURE ALARM.....	102
5.28.- LEAKAGE CURRENT ALARM.....	103
5.29.- NO. OF OPERATIONS ALARM.....	104
5.30.- SIMULATION SCREEN.....	105
6.- TECHNICAL FEATURES.....	106
7.- MAINTENANCE AND TECHNICAL SERVICE.....	109
8.- WARRANTY.....	109
9.- CE CERTIFICATE.....	110

REVISION LOG

Table 1: Revision log.

Date	Revision	Description
05/14	M015B01-03-14A	Initial Version
03/15	M015B01-03-15A	Modification in sections: 3.5. - 4.2. - 4.3. - 4.9. - 9
04/16	M015B01-03-15B	Modification in sections: 2 - 3.4. - 3.5. - 4.4. - 4.4.1. - 4.6.1.1. - 4.6.1.2. - 4.6.1.3. - 4.8. - 4.9.3. - 5.7. - 5.13. - 6.
03/18	M015B01-03-18A	Modification in sections: 4.9.3. - 5.14. - 9.
06/18	M015B01-03-18B	Modification in sections: 4.9.3.
01/20	M015B01-03-20A	Modification in sections: 2. - 4.4. - 4.5. - 4.9.3. - 5.14.
05/20	M015B01-03-20B	Modification in sections: 4.9.3. - 5.17.
01/21	M015B01-03-21A	Modification in sections: 4.6.1. - 4.9.3. - 5.3. - 5.13. - 5.23. - 5.24.

SYMBOLS

Table 2: Symbols

Symbol	Description
	In compliance with the relevant European directive.
	Device covered by European directive 2012/19/EC. At the end of its useful life, do not leave the unit in a household waste container. Follow local regulations on electronic equipment recycling.
	DC current
	AC current

Note: Devices images are for illustrative purposes only and may differ from the actual device.

1.- VERIFICATION UPON RECEPTION

Check the following points upon receiving the device:

- a) The device meets the specifications described in your order.
- b) The device has not suffered any damage during transport.
- c) Check the features shown on the label of the device to make sure that they are suitable for the type of power grid to which the device will be connected. (Voltage and power supply frequency, measurement range, etc.)
- d) Perform an external visual inspection of the device prior to switching it on.
- e) Check that it has been delivered with the following:
 - An installation guide,
 - Four retainers for rear attachment of the device,



If any problems are detected upon reception, immediately contact the transport company and/or the **CIRCUTOR S.A.** after-sales service.

2.- PRODUCT DESCRIPTION

The **Computer SMART III** reactive energy regulator is a device that measures the power grid cosine and controls capacitor connection and disconnection in order to correct it. It also calculates and displays the main electrical parameters of balanced or unbalanced single-phase and three-phase networks. The measurement is taken in RMS, via four AC voltage inputs and three current inputs.

There are 3 versions of the device, according to the number of output relays:

- ✓ **Computer SMART III 6**, with six output relays.
- ✓ **Computer SMART III 12**, with twelve output relays.
- ✓ **Computer SMART III 14**, with fourteen output relays.



The device features:

- **5 keys** that can be used to browse the various screens and program the device.
- **4 indicator LEDs**: CPU, ALARM, FAN and Key PRESSED.
- **LCD display**: amber backlit, 70x60.7-mm display for viewing all the parameters.
- **2 digital inputs**: for selecting the target cosine (4 target cosines).
- **2 digital outputs and 1 relay output**: completely programmable as alarms.
- **1 relay output**, specific for the fan.
- **6 output relays** (**Computer SMART III 6** model) ,**12 output relays** (**Computer SMART III 12**

model) or **14 output relays** (Computer SMART III 14 model) for regulating the $\cos \varphi$ by means of capacitors.

- **RS-485** communications, MODBUS RTU©.

3.- DEVICE INSTALLATION

3.1.- PRIOR RECOMMENDATIONS



In order to use the device safely, it is critical that individuals who handle it follow the safety measures set out in the standards of the country where it is being used, use the necessary personal protective equipment, and pay attention to the various warnings indicated in this instruction manual.

The **Computer SMART III** device must be installed by authorised and qualified staff.

The power supply plug must be disconnected and measuring systems switched off before handling, altering the connections or replacing the device. It is dangerous to handle the device while it is powered.

Also, it is critical to keep the cables in perfect condition in order to avoid accidents, personal injury and damage to installations.

The manufacturer of the device is not responsible for any damage resulting from failure by the user or installer to heed the warnings and/or recommendations set out in this manual, nor for damage resulting from the use of non-original products or accessories or those made by other manufacturers.

If an anomaly or malfunction is detected in the device, do not use it to take any measurements.

Inspect the work area before taking any measurements. Do not take measurements in dangerous areas or where there is a risk of explosion.



Disconnect the device from the power supply (device and measuring system power supply) before maintaining, repairing or handling the device's connections. Please contact the after-sales service if you suspect that there is an operational fault in the device.

3.2.- RECOMMENDATIONS FOR USING THE COMPUTER SMART III REGULATOR IN MEDIUM-VOLTAGE AUTOMATIC CAPACITOR BANKS

Computer SMART III regulators can also be used for controlling medium-voltage automatic capacitor banks, always under the full responsibility of the personnel responsible for starting it up, and taking into account the various recommendations mentioned below, which should be strictly observed in every case in order to avoid the possible appearance of problems in the various elements that make up the capacitor bank.



The voltage and current measurement signals must be supplied to the regulator from voltage and current transformers that are suitable for the tolerable ranges of the voltage and current measurement inputs of the regulator.



The stage connection and reclosing times must be adapted to the discharge time of the capacitors, and to the pre-determined operating rates, according to their specific features, for the capacitor bank operating elements. It is important to remember that excessively short connection times can cause serious damage to the components of the device.

Once the device is installed, select the High Voltage option in the programming menu (“5.10. - VOLTAGE LEVEL”).

When this option is selected the following functions are disabled in the device:

- ✓ The automatic programming function (Plug&Play).
- ✓ The function of automatically testing the status of the capacitors (AutoTest).
- ✓ The leakage current measurement and related alarms.

3.3.- INSTALLATION



The **Computer SMART III** regulator is connected to devices that contain capacitors, which are kept charged after the voltage is taken away. **Wait at least 5 minutes** after the device is disconnected before handling its internal components, in order to avoid the risk of electric shock.
Any manipulation or use of the device other than that specified by the manufacturer may compromise user safety.

Make sure that the devices are correctly earthed before they are connected. A faulty earth connection could lead to faulty operation and lead to a risk of electrical shock for the user or person handling the device.

Resonance can occur when the device is connected with no load. In this case, the voltage harmonics can be amplified, causing damage to the compensation device and other devices connected to the mains.

The persons responsible for installing or operating the **Computer SMART III** must follow common safety measures for LV or MV electrical installations in order to guarantee safe operation according to the installation location. In addition, they must take into account all the safety warnings stated in this instruction manual.

The device will be installed on a panel (138+1 x 138+1 mm panel boring, in compliance with DIN 43700). All connections are inside the electric panel.



Terminals, opening covers or removing elements can expose parts that are hazardous to the touch while the device is powered. Do not use the device until has been completely installed.

The device must be connected to a power circuit that is protected with gL fuses (IEC 269) or M fuses, with a rating of 0.5 to 2 A. It must be fitted with a circuit breaker or equivalent device for disconnecting the device from the power supply mains.

The power and voltage measurement circuits as well as the relay contact circuits must be connected with cables that have a minimum cross-section of 1.5 mm².

One or three external current transformers (CT) need to be installed in order to measure current. Usually, the transformation ratio of these CTs is $I_n/5$ A, where I_n is at least 1.5 times the total maximum load current.

The secondary cables of the current transformers (CT) must have a minimum cross-section of 2.5 mm^2 . For distances between the CTs and the device of more than 25 m, this cross-section should be increased by 1 mm^2 for every 10 m.

The current transformers (CTs) must be installed at the power line connection point which carries all the current of the loads to be compensated as well as the current that is specific to the capacitors (Figure 1).

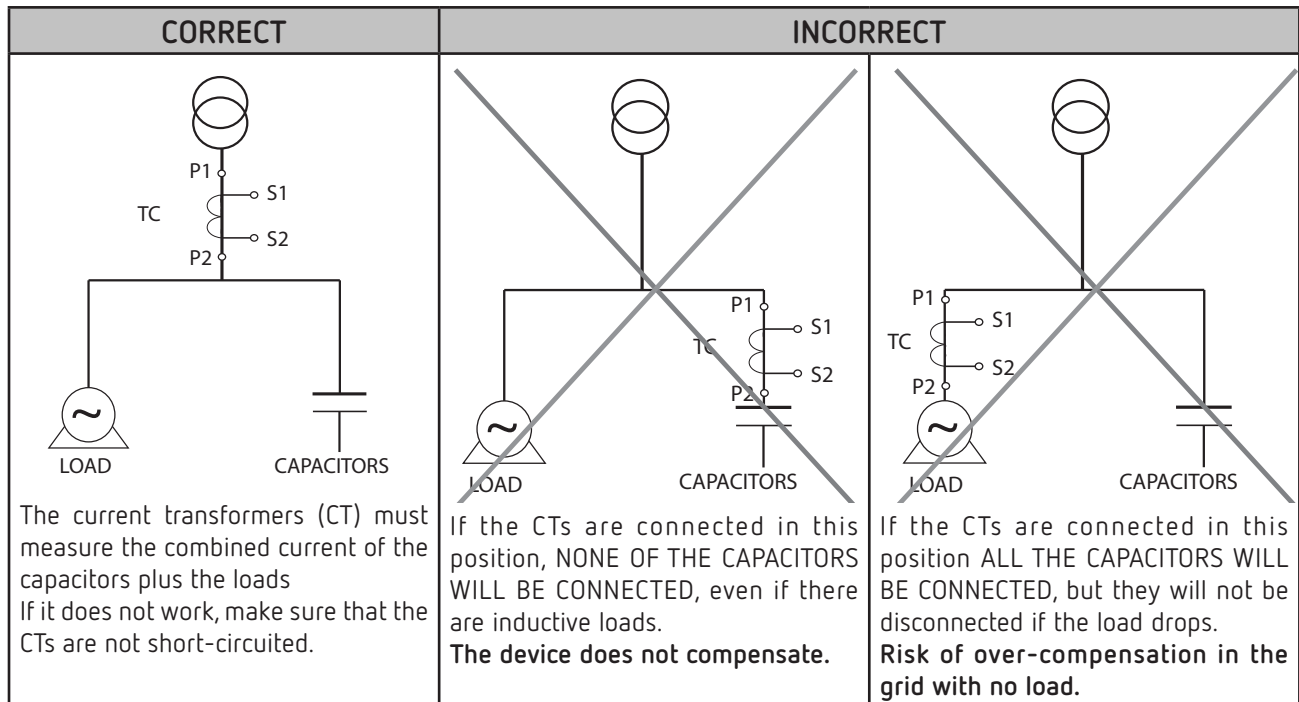

Figure 1: Location of the current transformers

3.4.- DEVICE TERMINALS

Table 3:List of Computer SMART III terminals

Terminals of the top side of the device	
1: A1, Auxiliary power supply.	23: R8, Relay output 8 (Computer SMART III 12 and 14 models)
2: A2, Auxiliary power supply.	24: R9, Relay output 9 (Computer SMART III 12 and 14 models)
3: V _{L1} , L1 voltage input	25: R10, Relay output 10 (Computer SMART III 12 and 14 models)
4: V _{L2} , L2 voltage input	26: R11, Relay output 11 (Computer SMART III 12 and 14 models)
5: V _{L3} , L3 voltage input	27: R12, Relay output 12 (Computer SMART III 12 and 14 models)
6: V _{LN} , Neutral voltage input	28: A(+), RS-485
7: S1, L1 current input	29: B(-), RS-485
8: S2, L1 current input	30: S, GND for RS-485
9: S1, L2 current input	31: 1, Digital input 1
10: S2, L2 current input	32: 1, Digital input 2
11: S1, L3 current input	33: C, Common to the digital inputs
12: S2, L3 current input	34: 1, Digital output 1
13: S1, Leakage current input	35: 2, Digital output 2
14: S2, Leakage current input	36: C, Common to the digital outputs
15: COM, Common relays	37: Fan relay output
16: R1, Relay output 1	38: Fan relay output
17: R2, Relay output 2	39: NC, Alarm relay output
18: R3, Relay output 3	40: C, Alarm relay output
19: R4, Relay output 4	41: NO, Alarm relay output
20: R5, Relay output 5	42: COM, Common relays
21: R6, Relay output 6	43: R12, Relay output 13 (Computer SMART III 14 model)
22: R7, Relay output 7 (Computer SMART III 12 and 14 models)	44: R12, Relay output 14 (Computer SMART III 14 model)

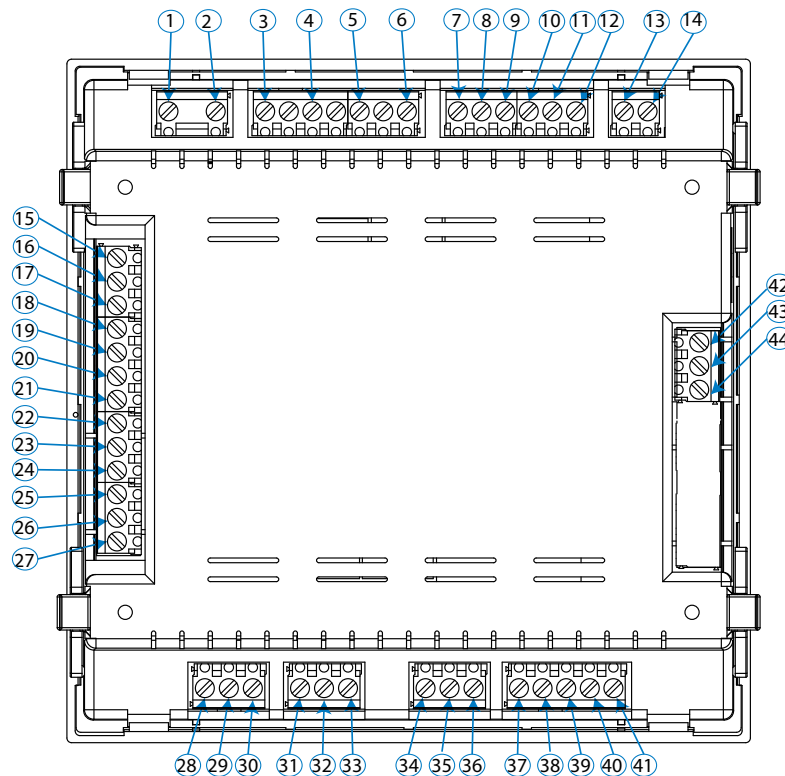

Figure 2: Computer SMART III terminals.

3.5.- CONNECTION DIAGRAM

3.5.1.- 3 voltages + neutral and 3 currents, Computer SMART III 6 model

Connection type: 3U.3C

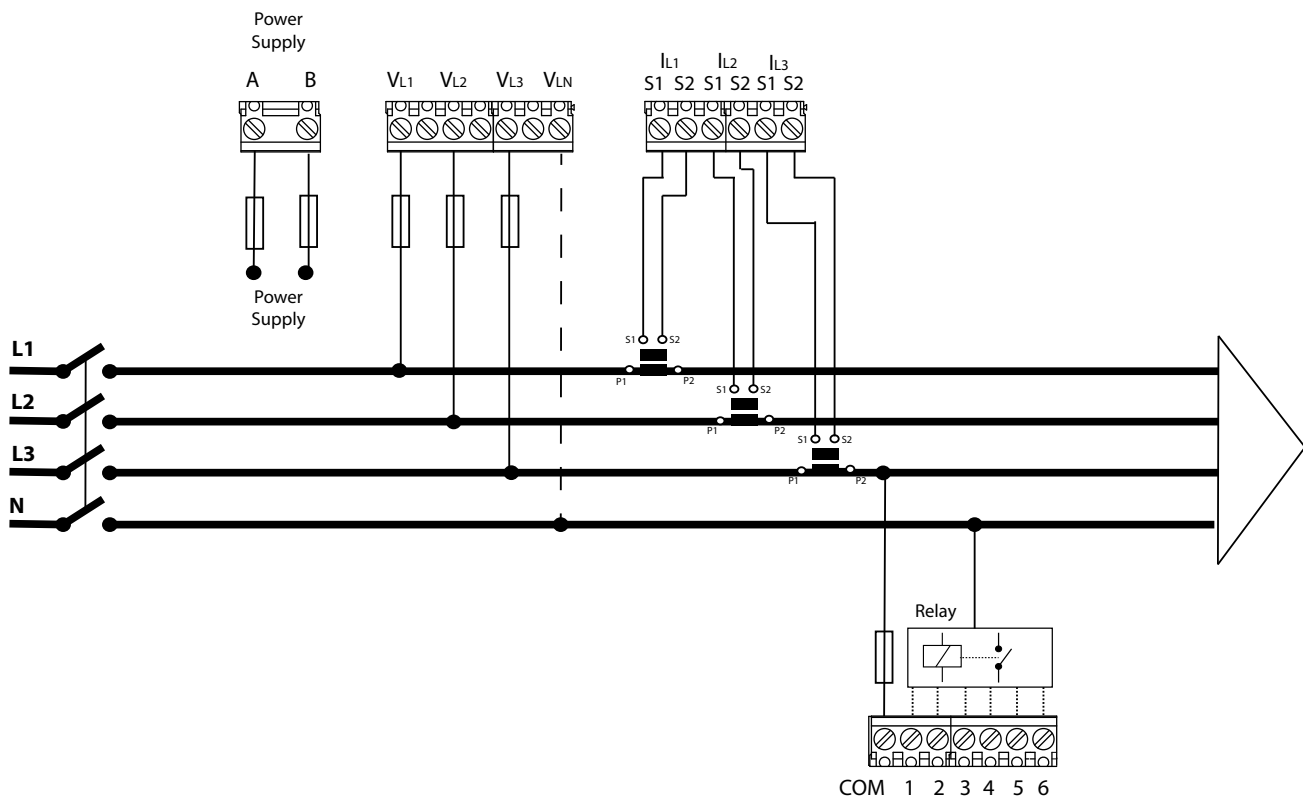

Figure 3: 3 voltages + neutral and 3 currents, Computer SMART III 6 model.

Note: If the connection layout mentioned above is not respected, the phase must be adjusted, following the procedure described in section "5.6.- PHASE CONNECTION"

Note: In this type of connection, the connection from Neutral to V_{LN} is not mandatory.

3.5.2.- 3 voltages + neutral and 3 currents, Computer SMART III 12 model

Connection type: 3U.3C

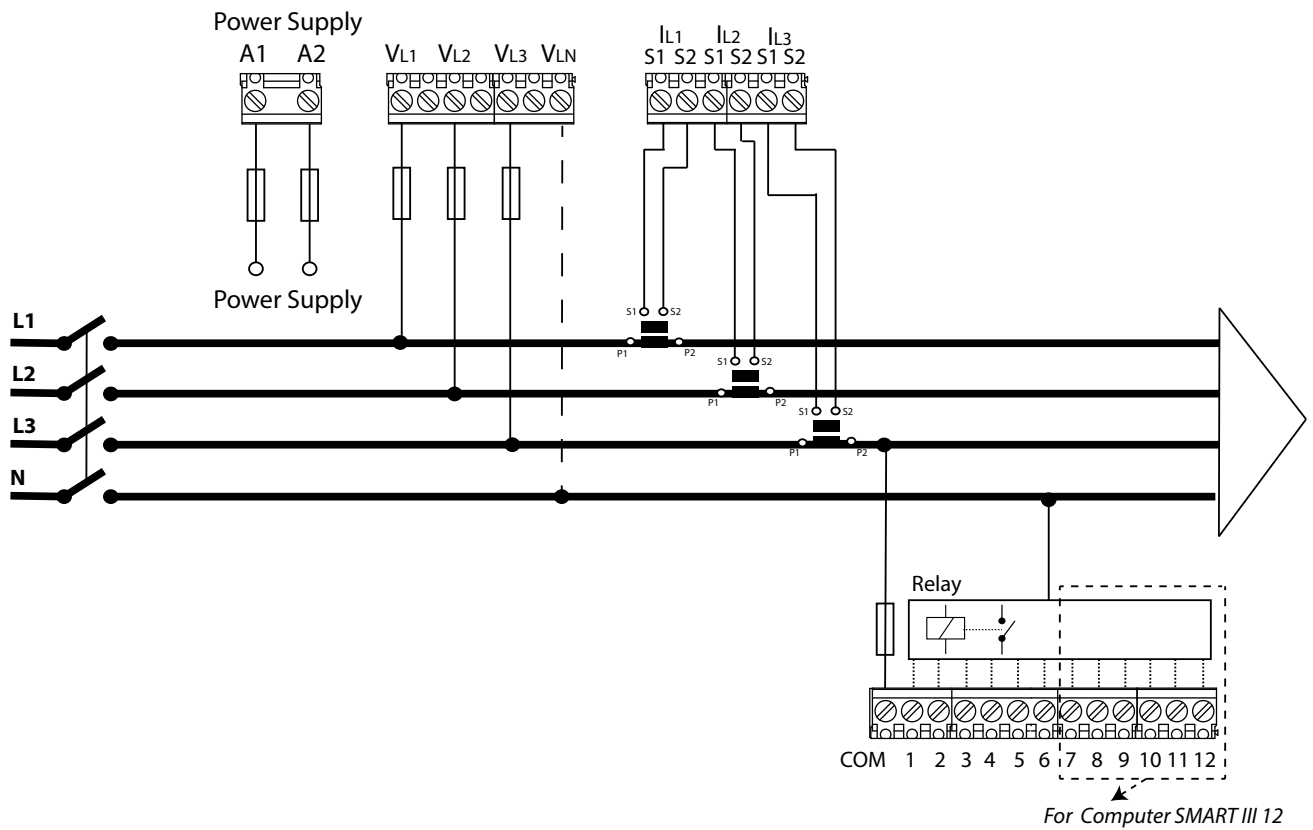

Figure 4: 3 voltages + neutral and 3 currents, Computer SMART III 12 model.

Note: If the connection layout mentioned above is not respected, the phase must be adjusted, following the procedure described in section "5.6.- PHASE CONNECTION"

Note: In this type of connection, the connection from Neutral to V_{LN} is not mandatory.

3.5.3.- 3 voltages + neutral and 3 currents, Computer SMART III 14 model

Connection type 3U.3C

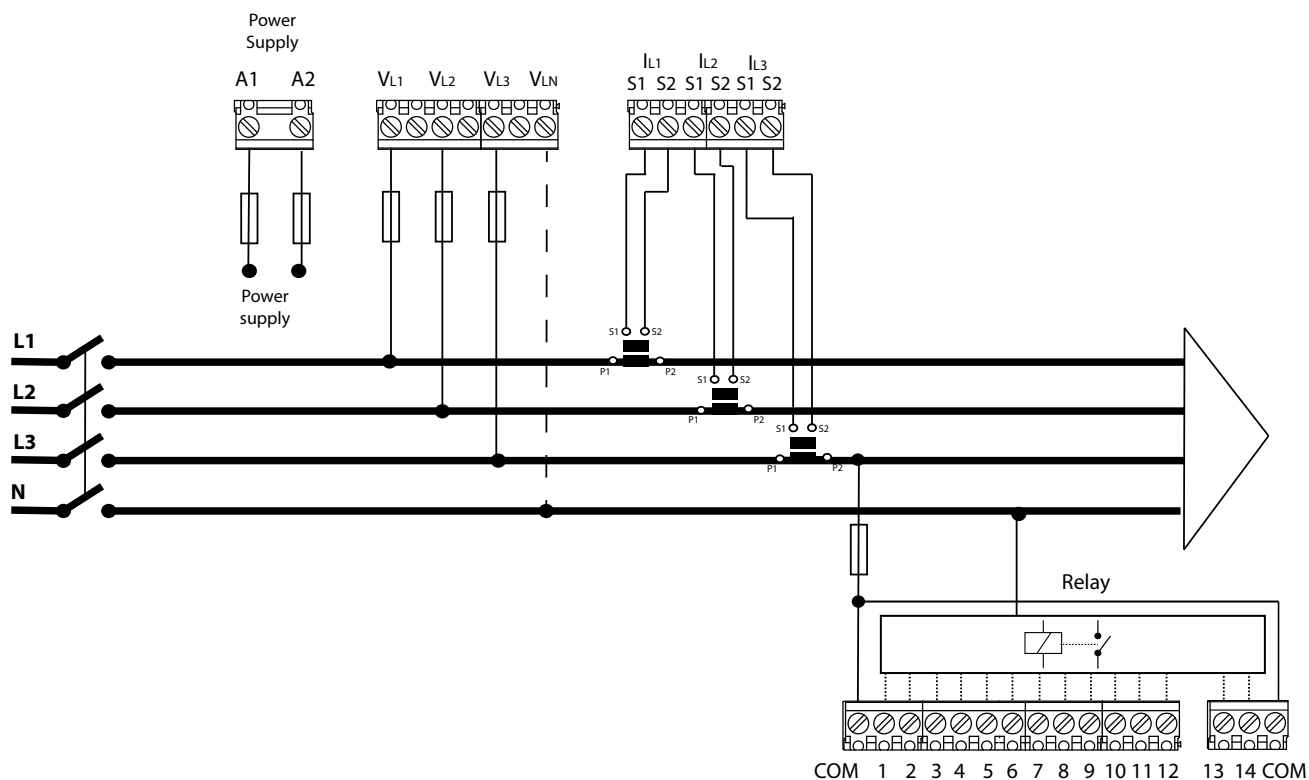

Figure 5: 3 voltages + neutral and 3 currents, Computer SMART III 14 model.

Note: If the connection layout mentioned above is not respected, the phase must be adjusted, following the procedure described in section "5.6.- PHASE CONNECTION"

Note: In this type of connection, the connection from Neutral to V_{LN} is not mandatory.

3.5.4.- 3 voltages + neutral and 1 current, Computer SMART III 6 model

Connection type: 3U. 1C

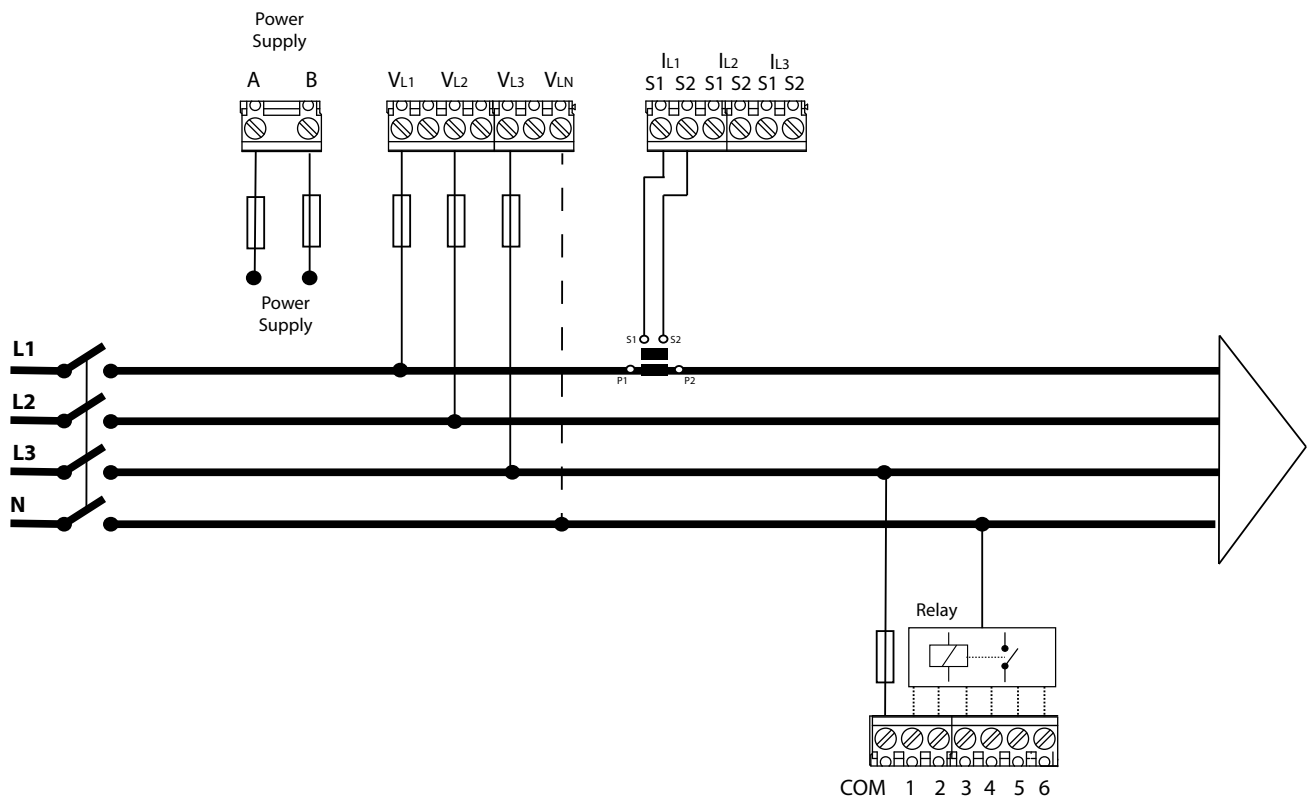

Figure 6: 3 voltages + neutral and 1 current, Computer SMART III 6 model.

Note: If the connection layout mentioned above is not respected, the phase must be adjusted, following the procedure described in section "5.6.- PHASE CONNECTION"

Note: In this type of connection, the connection from Neutral to V_{LN} is not mandatory.

Note: In this type of connection, the current transformer must be connected to the $IL1$ terminals.

3.5.5.- 3 voltages + neutral and 1 current, Computer SMART III 12 model

Connection type: 3U. 1C

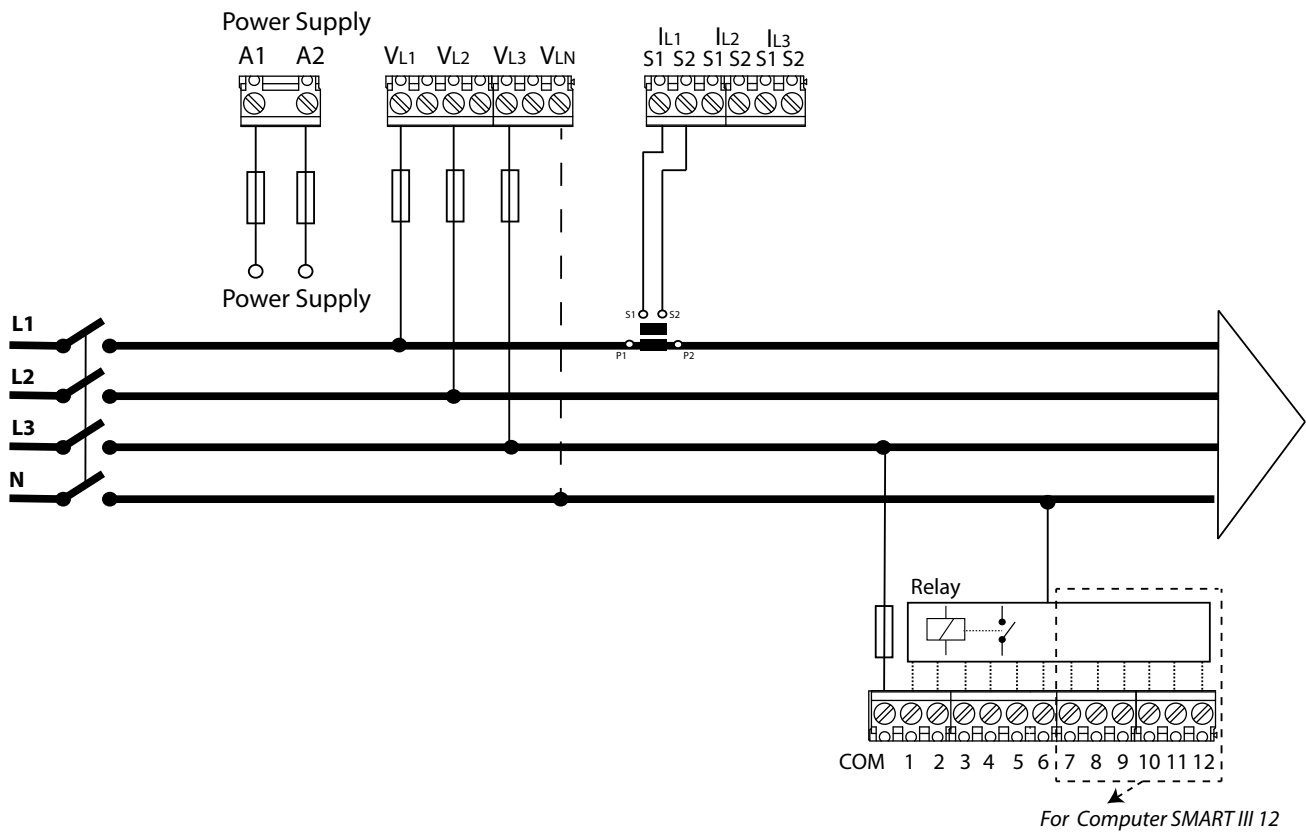

Figure 7: 3 voltages + neutral and 1 current, Computer SMART III 12 model.

Note: If the connection layout mentioned above is not respected, the phase must be adjusted, following the procedure described in section "5.6.- PHASE CONNECTION"

Note: In this type of connection, the connection from Neutral to V_{LN} is not mandatory.

Note: In this type of connection, the current transformer must be connected to the $IL1$ terminals.

3.5.6.- 3 voltages + neutral and 1 current, Computer SMART III 14 model

Connection type: 3U. 1C

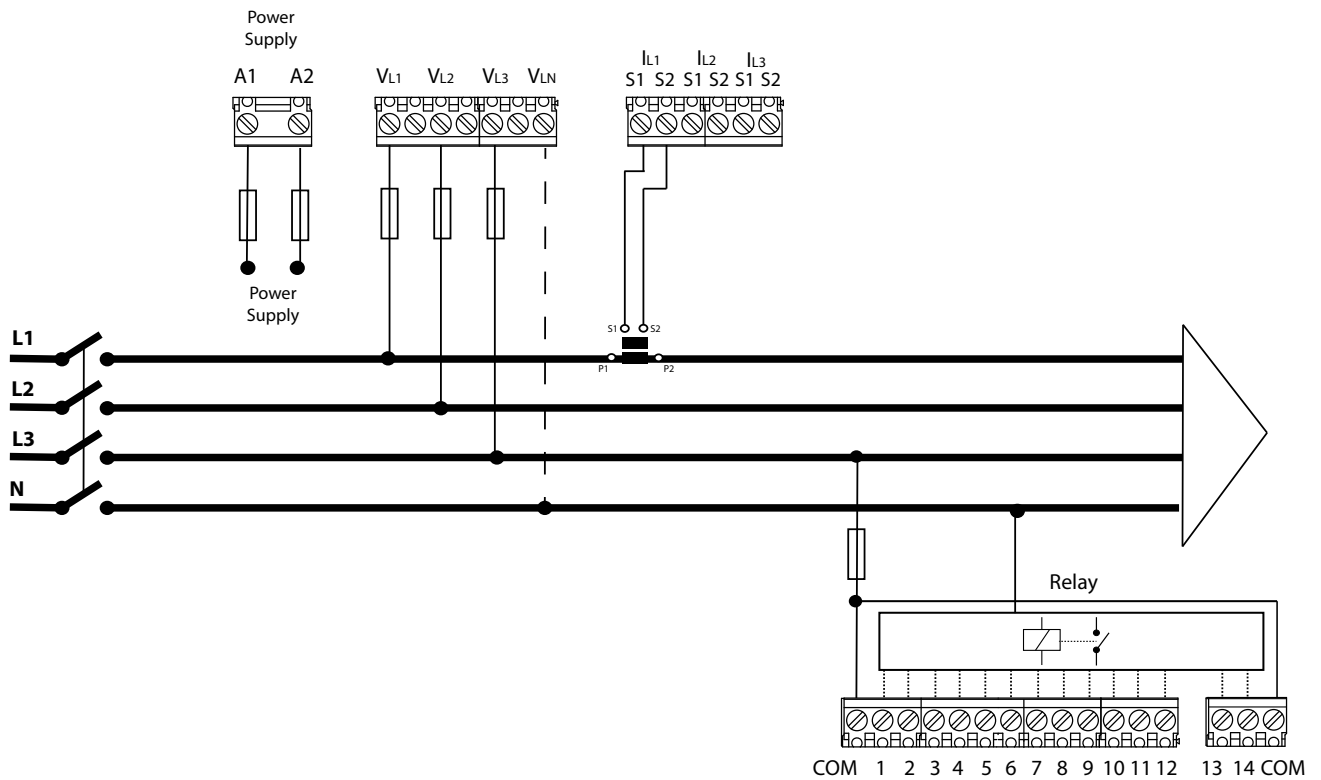

Figure 8: 3 voltages + neutral and 1 current, Computer SMART III 14 model.

Note: If the connection layout mentioned above is not respected, the phase must be adjusted, following the procedure described in section "5.6.- PHASE CONNECTION"

Note: In this type of connection, the connection from Neutral to V_{LN} is not mandatory.

Note: In this type of connection, the current transformer must be connected to the $IL1$ terminals.

3.5.7.- 2 voltages and 1 current, Computer SMART III 6 model

Connection type: 2U. 1C

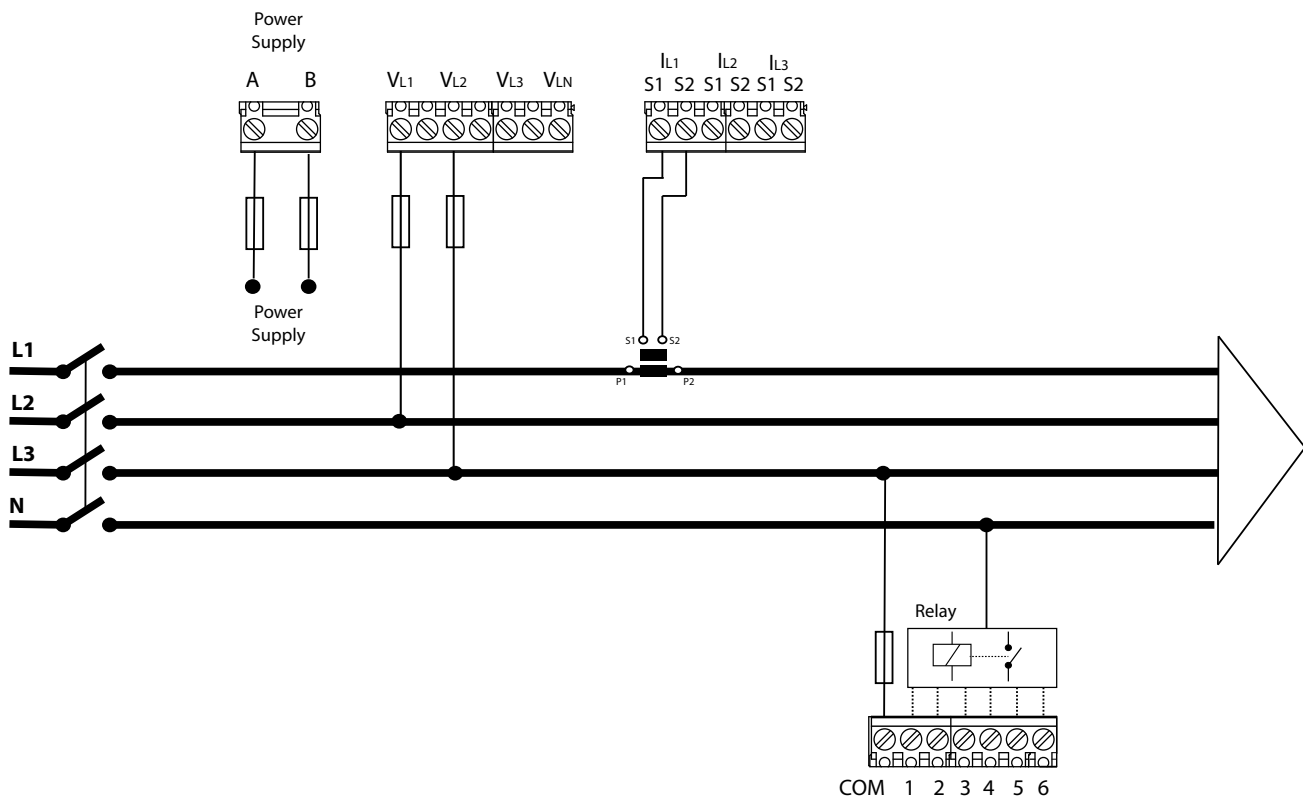

Figure 9: 2 voltages and 1 current, Computer SMART III 6 model.

Note: If the connection layout mentioned above is not respected, the phase must be adjusted, following the procedure described in section "5.6.- PHASE CONNECTION"

Note: In this type of connection, the Neutral connection is not necessary.

Note: In this type of connection, the current transformer must be connected to the IL1 terminals, and the two voltages must be connected to VL1 and VL2.

3.5.8.- 2 voltages and 1 current, Computer SMART III 12 model

Connection type: 2U. 1C

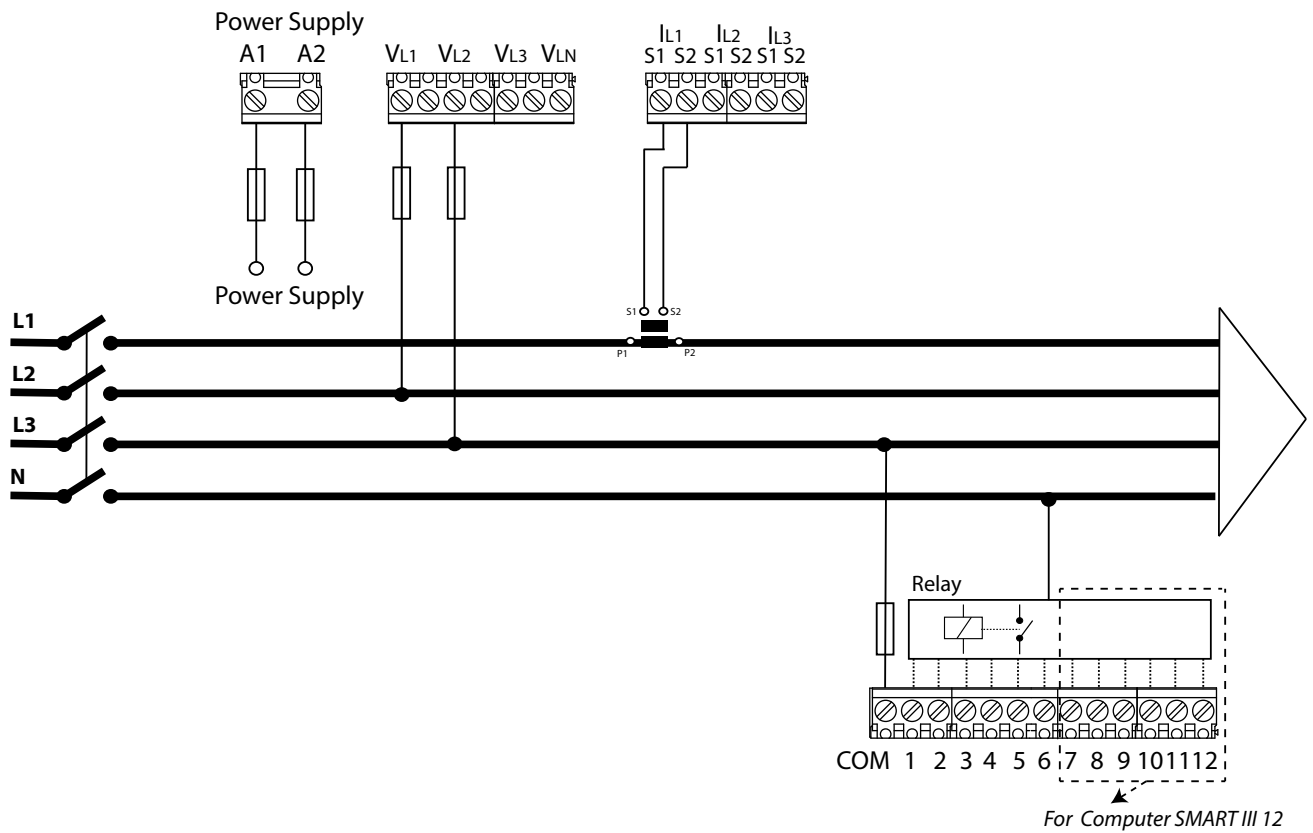

Figure 10: 2 voltages and 1 current, Computer SMART III 12 model.

Note: If the connection layout mentioned above is not respected, the phase must be adjusted, following the procedure described in section "5.6.- PHASE CONNECTION"

Note: In this type of connection, the Neutral connection is not necessary.

Note: In this type of connection, the current transformer must be connected to the IL1 terminals, and the two voltages must be connected to VL1 and VL2.

3.5.9.- 2 voltages and 1 current, Computer SMART III 14 model

Connection type: 2U. 1C

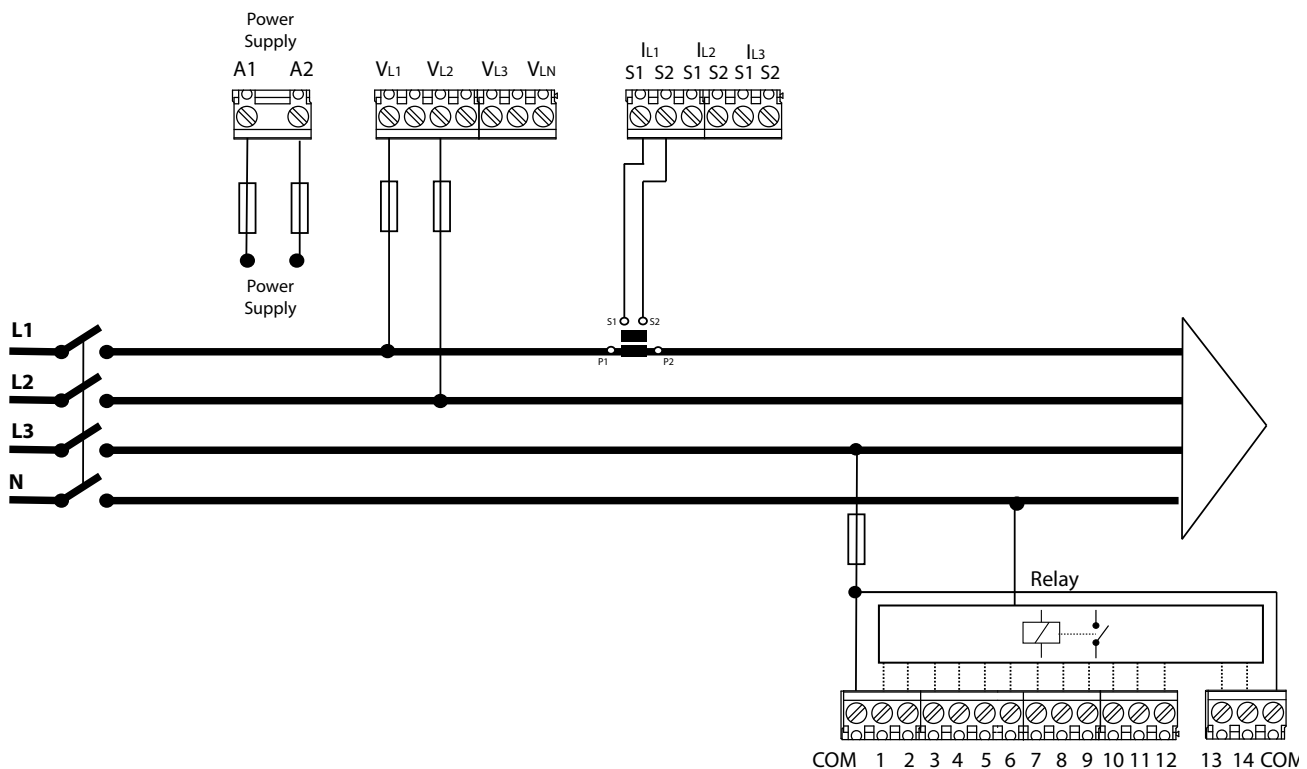

Figure 11: 2 voltages and 1 current, Computer SMART III 14 model.

Note: If the connection layout mentioned above is not respected, the phase must be adjusted, following the procedure described in section "5.6.- PHASE CONNECTION"

Note: In this type of connection, the Neutral connection is not necessary.

Note: In this type of connection, the current transformer must be connected to the IL1 terminals, and the two voltages must be connected to VL1 and VL2.

3.5.10.- Leakage current connection, I_{Δ}

To measure the leakage current, an earth leakage transformer must be used, such as **WGS**. The leakage current transformer must be connected such as to measure the current of the capacitor bank. This will detect any leakage in the capacitors of the capacitor bank.

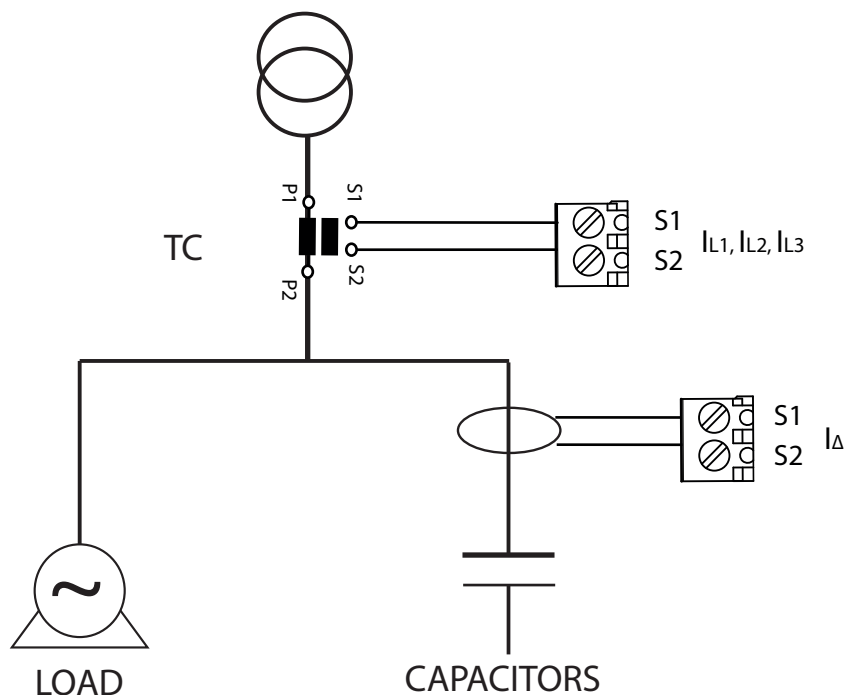

Figure 12: Connection of the leakage current transformer (I_{Δ}).

Note: The earth leakage transformer must have a ratio of 500 turns. The maximum leakage current that the device can measure correctly is 1.5A AC, even though the maximum input is 5A AC via the earth leakage transformer.

	<p>Do not operate the leakage current transformer with the Computer SMART III powered on.</p>
--	--

3.6.- STARTING UP THE DEVICE

Once the **Computer SMART III** is powered on, the following screen appears on the display, **Figure 13**, which shows the name of the device, the version and the model.



Figure 13: Computer SMART III home screen.

After a few seconds, the main measurement screen appears.

4.- OPERATION

The **Computer SMART III** is a reactive energy regulator. The device measures the $\cos \varphi$ of the mains and regulates the connection and disconnection of capacitors, via the relays, in order to correct it. The control is carried out at the four quadrants, **Figure 14**.

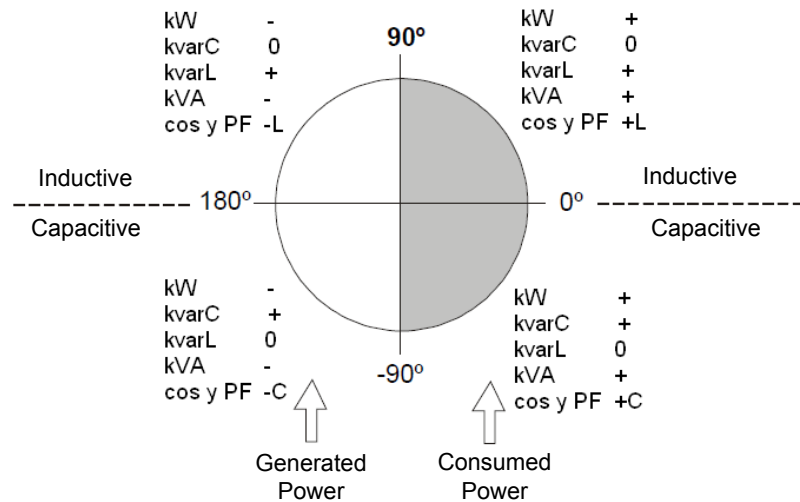

Figure 14: Measurement and Compensation at the four quadrants.

In addition to the basic functions of any regulator, the **Computer SMART III**:

- ✓ Performs the functions of a network analyzer, measuring and viewing multiple parameters.
- ✓ Has a Plug&Play function for automatic configuration of the device.
- ✓ Has an AutoTest and manual test function for testing the status of the capacitors of the capacitor bank.
- ✓ Has an FCP system, which minimises the number of connections and disconnections of the relays.
- ✓ Supports step forcing.
- ✓ Can work with various connection types.
- ✓ Measures leakage current with the option of associating an alarm and conducting a search and cancellation of the faulty capacitor.
- ✓ Has multiple alarms, for warning of possible faults, whether in the capacitor bank or in the installation.

4.1.- DEFINITIONS

This section provides a number of definitions that may be useful for understanding the operation of the device.

4.1.1. Four-quadrant regulator

The regulator is capable of performing the measurement and regulation functions when the active power is transferred from the mains to the loads (common case in a consumer installation) or when the load is transferred to the mains (in the case of installations with generators that not only allow the consumption of energy, but can also export and sell energy).

4.1.2. Stages and steps

A distinction must be established between stages and steps. In this manual, a **Stage** is described as each group of capacitor banks into which the power factor compensation device is divided, which may have different power ratings, usually in ratios of 1:1, 1:2, 1:2:4, etc.

A **step** is each one of the total power fractions (power of the first step) that can be regulated by using stages with different weights.

4.1.3. FCP system (FAST Computerized Program)

This system controls the connection sequence of the various stages, tending to minimise the number of operations and to match the usage times of the various stages in order to achieve a pre-determined required final power. The operations are carried out such that, in the case of stages with identical power, the stage that has been disconnected the longest is connected when there is demand and the stage that has been connected the longest is disconnected when there is a surplus.

4.1.4. Regulation program

The power ratings of the various groups or stages usually follow certain patterns called "programs".

The program indicates the power ratios between the various stages. The most frequent programs are:

Program 1.1.1.1 . All stages have the same power. *For example: a 100 kvar unit with 5 steps would be made up of 5 identical 20 kvar stages, and would be described as a (5 x 20) kvar unit.*

Program 1.2.2.2 . Every stage after the first stage has twice as much power as the first stage. *For example: a 180 kvar unit with 5 stages would be made up of a first 20 kvar stage and 4 identical 40 kvar stages, and would be described as a (20 + 4 x 40) kvar unit.*

Program 1.2.4.4 . The second stage has twice as much power as the first stage and the remaining stages after the second stage have four times as much power as the first stage. *For example: a 300 kvar unit with 5 stages would be made up of a first 20 kvar stage, a second 40 kvar stage and 3 identical 80 kvar stages. It would be described as a (20 + 40 + 3 x 80) kvar unit.*

Other Programs. Other programs can be used, such as 1.2.2.4, 1.2.4.8, 1.1.2.2, etc. The meaning of the numbers, as can be deduced from the preceding cases, gives the power ratio between the first stage, which receives a value of 1, and the subsequent stages (2 means twice as much power, 4 means four times as much power, etc.).

The device can be used to configure programs from 1.1.1.1 to 1.9.9.9.

4.1.5. Plug and Play

When a reactive energy regulator is installed, a series of parameters need to be configured in order to ensure that it operates correctly. Some of these parameters might be difficult to discover, for example such as the voltage phases or the correspondence between measured current and its voltage, as well as the current transformer ratio. The **Computer SMART III** includes an automatic process which intelligently works out necessary parameters such as:

- ✓ **Connection type:** detects the connection type used from among the possible options: $3U.3C$, $3U.1C$ and $2U.1C$.
- ✓ **Phase:** identifies the correspondence between the voltages and the currents connected, regardless of the connection type detected previously.
- ✓ **Number of stages installed and program:** sequentially connects all the stages to work out how many stages are installed and calculates the program, in other words the power ratio between the capacitors.
- ✓ **C/K:** calculates the ratio between the current transformer and the power of the smallest step.

4.1.6. Connection time (Ton) and reclosing time (Trec)

Connection time, Ton, defines the shortest possible time between changes in the status of the stages, in other words, between connections and disconnections. Therefore, the configuration of this parameter has a direct impact on the compensation speed, in other words, on the capacity for monitoring load changes. Setting a shorter connection time improves the power factor correction when the load can change quickly.

However, a shorter **Ton** will lead to a higher number of connections per time unit, possibly shortening the useful life of the associated components (contactors, capacitors). To assess the number of connections, **Computer SMART III** uses individual meters for each stage.

Reclosing time, Trec, is the shortest possible time between disconnecting a stage and reclosing it. This time is necessary for the capacitor to discharge enough so that, when it is reclosed, it does not cause overcurrents in the system.

4.1.7. THD and harmonics

Non-linear loads, such as those in rectifiers, inverters, speed drives, kilns, etc., absorb non-sinusoidal periodic currents from the mains. These currents are made up of a fundamental component with a frequency of 50 or 60 Hz, plus a series of overlapping currents, with frequencies that are multiples of the fundamental frequency; these are defined as harmonics. The result is a deformation of the current and, thus, of the voltage, which leads to a series of related side effects (conductor overload, circuit breakers and machines, phase offsets, interferences in electronic units, RCCB trips, etc.).

The level of harmonics is usually measured with the total harmonic distortion rate (THD), which is the ratio, usually as a %, of the RMS value of the harmonic content and the value of the fundamental component.

4.2.- MEASUREMENT PARAMETERS

The device displays the following electrical parameters:

4.2.1. Connection type: 3U.3C

Table 4: Computer SMART III measurement parameters (3U.3C connection)

Parameter	Units	Phases L1-L2-L3	N	Total III	Max ⁽¹⁾	Min ⁽²⁾
Phase-neutral voltage	V	✓		✓	✓	✓
Phase-phase voltage	V	✓		✓	✓	✓
Current	A	✓	✓		✓	✓
Leakage current	mA		✓		✓	✓
Frequency	Hz	✓(L1)			✓	✓
Active Power	M/kW	✓		✓	✓	✓
Apparent Power	M/kVA	✓		✓	✓	✓
Total Reactive Power	M/kvar	✓		✓	✓	✓
Inductive Reactive Power	M/kvarL	✓		✓	✓	✓
Capacitive Reactive Power	M/kvarC	✓		✓	✓	✓
Power factor	PF	✓		✓	✓	✓
Cos φ	φ	✓		✓	✓	✓
Voltage THD %	% THD V	✓			✓	
Current THD %	% THD A	✓			✓	
Harmonic Breakdown - Voltage (up to the 17th harmonic)	harm V	✓			✓	
Harmonic Breakdown - Current (up to the 17th harmonic)	harm A	✓			✓	
Active Energy	M/kWh			✓		
Inductive Reactive Energy	M/kvarLh			✓		
Capacitive Reactive Energy	M/kvarCh			✓		
Apparent energy	M/kVAh			✓		
Temperature	°C			✓		
No. of operations	(x 1000)			✓		
Total activated power	%			✓		

⁽¹⁾ Displays maximum value.

⁽²⁾ Displays minimum value.

4.2.2. Connection type: 3U. 1C

Table 5: Computer SMART III measurement parameters (3U. 1C connection)

Parameter	Units	Phases L1-L2-L3	N	Total III	Max ⁽³⁾	Min ⁽⁴⁾
Phase-neutral voltage	V	✓		✓	✓	✓
Phase-phase voltage	V	✓		✓	✓	✓
Current	A	✓(L1)			✓	✓
Leakage current	mA		✓		✓	✓
Frequency	Hz	✓(L1)			✓	✓
Active Power	M/kW			✓	✓	✓
Apparent Power	M/kVA			✓	✓	✓
Total Reactive Power	M/kvar			✓	✓	✓
Inductive Reactive Power	M/kvarL			✓	✓	✓
Capacitive Reactive Power	M/kvarC			✓	✓	✓
Power factor	PF			✓	✓	✓
Cos φ	φ			✓	✓	✓
Voltage THD %	% THD V	✓			✓	
Current THD %	% THD A	✓(L1)			✓	
Harmonic Breakdown - Voltage (up to the 17th harmonic)	harm V	✓			✓	
Harmonic Breakdown - Current (up to the 17th harmonic)	harm A	✓(L1)			✓	
Active Energy	M/kWh			✓		
Inductive Reactive Energy	M/kvarLh			✓		
Capacitive Reactive Energy	M/kvarCh			✓		
Apparent energy	M/kVAh			✓		
Temperature	°C			✓		
No. of operations	(x 1000)			✓		
Total activated power	%			✓		

⁽³⁾ Displays maximum value.⁽⁴⁾ Displays minimum value.

4.2.3. Connection type: 2U. 1C

Table 6: Computer SMART III measurement parameters (2U. 1C connection)

Parameter	Units	Phases L1-L2-L3	N	Total III	Max ⁽⁵⁾	Min ⁽⁶⁾
Phase-neutral voltage	V					
Phase-phase voltage	V			✓(L1-L2)	✓	✓
Current	A	✓(L1)			✓	✓
Leakage current	mA		✓		✓	✓
Frequency	Hz	✓(L1)			✓	✓
Active Power	M/kW			✓	✓	✓
Apparent Power	M/kVA			✓	✓	✓
Total Reactive Power	M/kvar			✓	✓	✓
Inductive Reactive Power	M/kvarL			✓	✓	✓
Capacitive Reactive Power	M/kvarC			✓	✓	✓
Power factor	PF			✓	✓	✓
Cos φ	φ			✓	✓	✓
Voltage THD %	% THD V	✓(L1-L2)			✓	
Current THD %	% THD A	✓(L1)			✓	
Harmonic Breakdown - Voltage (up to the 17th harmonic)	harm V	✓(L1-L2)			✓	
Harmonic Breakdown - Current (up to the 17th harmonic)	harm A	✓(L1)			✓	
Active Energy	M/kWh			✓		
Inductive Reactive Energy	M/kvarLh			✓		
Capacitive Reactive Energy	M/kvarCh			✓		
Apparent energy	M/kVAh			✓		
Temperature	°C			✓		
No. of operations	(x 1000)			✓		
Total activated power	%			✓		







⁽⁵⁾ Displays maximum value.⁽⁶⁾ Displays minimum value.

4.3.- KEYBOARD FUNCTIONS

The **Computer SMART III** has 5 keys that can be used to browse between the various screens and program the device.

Keys functions on the measurement screens (**Table 7**):







Table 7: Keys functions on the measurement screens.

Key	Short keystroke	Long keystroke (3 s)
	Previous screen	-
	Next screen	-
	View minimum value	Delete minimum values
	View maximum value	Delete maximum values
	Next parameter	Enter the programming menu
 	Very long keystroke (10 s.) Enter the Test screens	

Note: See "4.6.1. MEASUREMENT STATUS" for further details.

Keys functions on the Configuration and Test screens, query mode (**Table 8**):





Table 8: Keys functions on the Configuration and Test screens, query mode.

Key	Short keystroke	Long keystroke (3 s)
	Previous screen	Test: Manual connection of the selected capacitor
	Next screen	Test: Manual disconnection of the selected capacitor
	Previous parameter	
	Next parameter	
	Configuration: Edit mode Test: Start AutoTest	Test: Cancel the AutoTest process
 	Very long keystroke (10 s.) Exit the Test screens	

Note: See "4.6.2. TEST STATUS" and "5.- CONFIGURATION" for further details.

Keys functions on the Configuration and Test screens, edit mode (Table 9):

Table 9: Keys functions on the Configuration and Test screens, edit mode.

Key	Short keystroke
	Increase the value or show the next option.
	Reduce the value or show the previous option.
	Previous configuration parameter
	Next configuration parameter
	Exit Edit mode

Note: See "4.6.2. TEST STATUS" and "5.- CONFIGURATION" for further details.

4.4.- DISPLAY

The device has a backlit LCD display. The display is divided into four areas (Figure 15):

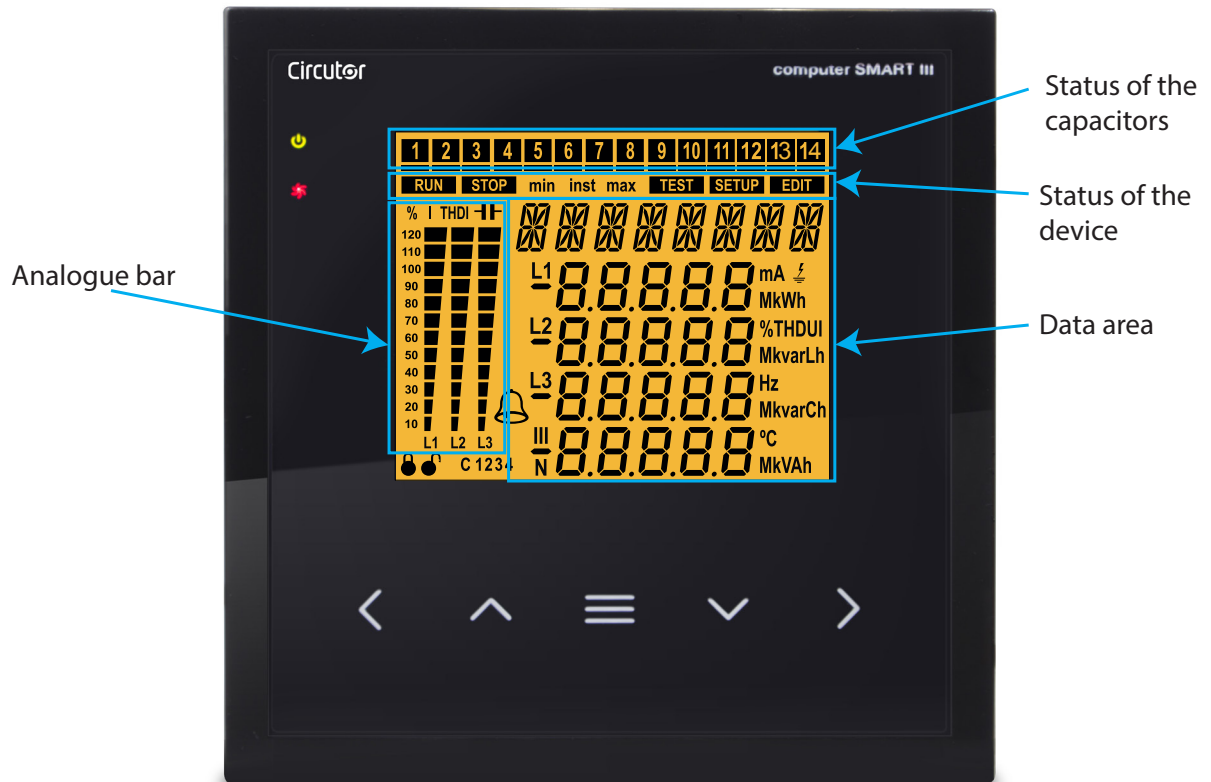

Figure 15: Areas of the Computer SMART III display.

- ✓ The **data area**: displays the instantaneous, maximum and minimum values of each one of the phases which the device is measuring or calculating.
- ✓ **Status of the capacitors**: displays the status of the relays of the device.
- ✓ **Status of the device**: displays the current status of the device.
- ✓ **Analogue bar**: configurable, shows the current, current THD or connected power of the capacitor bank as a %.

4.4.1. STATUS OF THE CAPACITORS



Figure 16: Status of the capacitors.

This area shows the status of the relays (stages) of the device, and thus of the capacitors connected to it.

The possible states are:

- ✓ Nothing is displayed if the stage is not connected and configured as *AUTO*.
- ✓ The **1** icon is displayed if the stage is connected and configured as *AUTO*.
- ✓ The **1** icon is displayed with the bottom bar steady if the stage is connected and configured as *ON*.
- ✓ The **1** icon is displayed with the bottom bar flashing if the stage is connected and configured as *ON nC*.
- ✓ Only the steady bottom bar is displayed if the stage is disconnected and configured as *OFF*.
- ✓ Only the flashing bottom bar is displayed if the stage is cancelled by the leakage current alarm, E15.

In the setup menu ("*5.14.- STATUS OF THE STAGES*") the status of the stages is selected from the following options:

- ✓ *AUTO*: The status of the stage depends on the operation performed by the device.
- ✓ *ON*: Stage forced to ON, always connected.
- ✓ *OFF*: Stage forced to OFF, always disconnected.
- ✓ *ON nC*: Stage forced to ON, always connected but the system does not take into account its connected power.

By default, all the stages are configured as *AUTO*.

4.4.2. STATUS OF THE DEVICE

This area displays the status of the device in accordance with the following icons:

- RUN** The device is in measurement and regulation mode.
- STOP** The device does not measure or regulate.
- SETUP** Indicates that you are in the setup menu.
- TEST** Indicates that you are in the test menu.
- EDIT** Indicates that, within the setup menu, you are in edit mode.

inst Indicates that you are viewing the instantaneous value.

max Indicates that you are viewing the maximum value.

min Indicates that you are viewing the minimum value.

4.4.3. ANALOGUE BAR

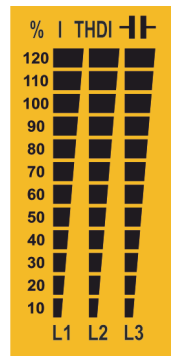

Figure 17: Analogue Bar

This bar is displayed on the measurement screens, and can show:

- ✓ the current of each phase as a %.
- ✓ the current THD of each phase.
- ✓ the power connected to the capacitor bank.

The parameter to be displayed is selected in the setup menu. ("**5.16. - ANALOGUE BAR**")



The display screen also shows the results of the TEST and the load % of the capacitors.

4.4.4. OTHER SYMBOLS OF THE DISPLAY

The display also shows the following:

 **Alarm:** When the device detects an alarm, the backlight of the screen flashes and the alarm icon lights up. The cause of the alarm can be seen on the active alarms screen. ("**4.6. - OPERATING STATES**")

 **Target cosine:** The icons indicate which one of the four possible target cosines have been selected. ("**5.3. - TARGET COS ϕ** ")

  **Editing locked / unlocked:** The editing of the programming parameters is password protected. These icons indicate whether or not this option is locked.

4.5.- LED INDICATORS

The **Computer SMART III** device comprises:

- ✓ A **CPU** LED: Indicates that the device is working properly by flashing once per second.
- ✓ An **Alarm** LED: Indicates that an alarm is activated.
- ✓ A **Fan** LED: Indicates that the fan is operating.
- ✓ A **Key pressed** LED: Lights up when any of the five keys are pressed.

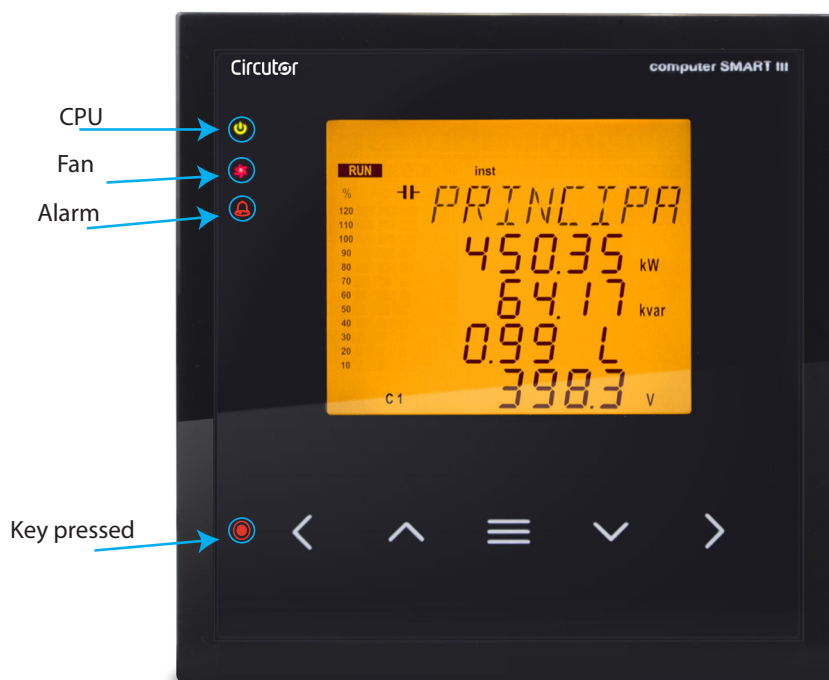

Figure 18: LED indicators of the Computer SMART III.

4.6.- OPERATING STATES

The **Computer SMART III** has two operating states with the display screens matching the selected status:

- ✓ Measurement status, **RUN**,
- ✓ Test status, **TEST**,

4.6.1. MEASUREMENT STATUS

This status is identified by the **RUN** symbol in the device status area of the display (**Figure 15**). It is the normal operating status of the **Computer SMART III**, in which the device measures the various grid parameters and acts according to the configured parameters, connecting or disconnecting the capacitors from the capacitor bank.

Use keys  and  to browse the various screens.

Note: If the hysteresis of the target $\cos \varphi$ is activated, the symbol **RUN** flashes on the display screens every 5 seconds.

Delete maximum values:

On the maximum value display screen, press the  key for more than 3 seconds.



Delete minimum values:

On the minimum value display screen, press the  key for more than 3 seconds.

If 5 minutes pass without any keys being pressed, the device returns to the main screen.

The display screens vary according to the connection type of the installation.

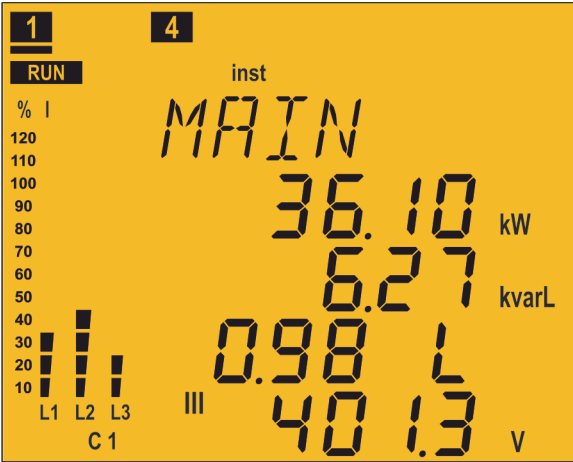
4.6.1.1. 3U.3C Connection (3 Voltages + Neutral and 3 currents)

Main Screen	Parameters
	<p>Active Power III(kW or MW) Reactive Power III(kvar or Mvar) Cos φ L: Inductive / C: capacitive +: consumed / -: generated Phase - Phase Voltage III(V or kV)</p> <p> Display the minimum values.  Display the maximum values.</p>

Press the  key to switch to the **Currents** screen.

Phase - Neutral Voltages	Parameters
	<p>L1 Phase - Neutral Voltage (V or kV) L2 Phase - Neutral Voltage (V or kV) L3 Phase - Neutral Voltage (V or kV) Phase - Neutral Voltage III(V or kV)</p> <p>◀ Display the minimum values. ▶ Display the maximum values.</p>

Phase - Phase Voltages	Parameters
	<p>L1 Phase - Phase Voltage (V or kV) L2 Phase - Phase Voltage (V or kV) L3 Phase - Phase Voltage (V or kV) Phase - Phase Voltage III(V or kV)</p> <p>◀ Display the minimum values. ▶ Display the maximum values.</p>

Currents	Parameters
	<p>L1 Current (A) L2 Current (A) L3 Current (A) N Current (A)</p> <p>◀ Display the minimum values. ▶ Display the maximum values.</p>

Press the or key to switch to the Cosine ϕ screen.

Cosine ϕ	Parameters
	<p>L1 Cos ϕ L2 Cos ϕ L3 Cos ϕ Cos ϕ III L: Inductive / C: capacitive +: Consumed / -: generated</p> <p> Display the minimum values. Display the maximum values.</p>

Press the key to switch to the Energy III consumed screen.

Power Factor	Parameters
	<p>L1 Power Factor L2 Power Factor L3 Power Factor Power Factor III L: Inductive / C: capacitive +: Consumed / -: generated</p> <p> Display the minimum values. Display the maximum values.</p>

Power III	Parameters
	<p>Active Power III (kW or MW) Inductive Reactive Power III (kvarL or MvarL) Capacitive Reactive Power III (kvarC or MvarC) Apparent Power III (kVA or MVA)</p> <p> Display the minimum values. Display the maximum values.</p>

Active Power	Parameters
	<p>L1 Active power (kW or MW) L2 Active power (kW or MW) L3 Active power (kW or MW) Active Power III(kW or MW)</p> <p>◀ Display the minimum values. ▶ Display the maximum values.</p>

Inductive Reactive Power	Parameters
	<p>L1 Inductive Reactive Power L2 Inductive Reactive Power L3 Inductive Reactive Power Inductive Reactive Power III (kvarL or MvarL)</p> <p>◀ Display the minimum values. ▶ Display the maximum values.</p>

Capacitive Reactive Power	Parameters
	<p>L1 Capacitive Reactive Power L2 Capacitive Reactive Power L3 Capacitive Reactive Power Capacitive Reactive Power III (kvarC or MvarC)</p> <p>◀ Display the minimum values. ▶ Display the maximum values.</p>

Apparent Power	Parameters
	<p>L1 Apparent Power L2 Apparent Power L3 Apparent Power Apparent Power III (kVA or MVA)</p> <p>◀ Display the minimum values. ▶ Display the maximum values.</p>

Leakage current / Frequency / Temperature	Parameters
	<p>Leakage current (mA) Frequency (Hz) Temperature (°C)</p> <p>◀ Display the minimum values. ▶ Display the maximum values.</p>

Voltage THD	Parameters
	<p>L1 Voltage THD L2 Voltage THD L3 Voltage THD (%)</p> <p>▶ Display the maximum values.</p>

Voltage harmonics	Parameters
	<p>L1 Voltage harmonic L2 Voltage harmonic L3 Voltage harmonic (%)</p> <p> Change the harmonic no.: 3, 5, 7, 9, 11, 13, 15, 17.</p> <p> Display the maximum values.</p>

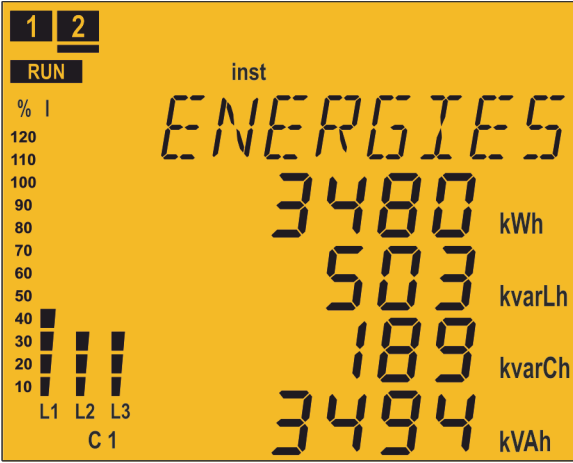

Current THD	Parameters
	<p>L1 Current THD L2 Current THD L3 Current THD (%)</p> <p> Display the maximum values.</p>

Current harmonics	Parameters
	<p>L1 Current harmonic L2 Current harmonic L3 Current harmonic (%)</p> <p> Change the harmonic no.: 3, 5, 7, 9, 11, 13, 15, 17.</p> <p> Display the maximum values.</p>

Energy III consumed	Parameters
	<p>Active Energy III consumed (kWh or MWh) Inductive Reactive Energy III consumed (kvarLh or MvarLh) Capacitive Reactive Energy III consumed (kvarCh or MvarCh) Apparent Energy III consumed (kVAh or MVAh)</p>

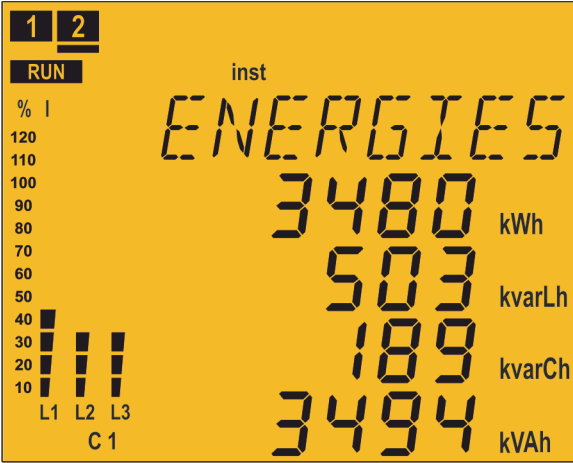
Press the  key to switch to the Main screen.

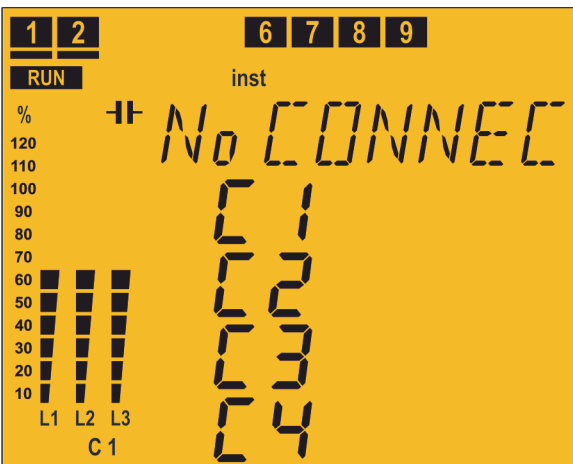
Energy III generated	Parameters
	<p>Active Energy III generated (kWh or MWh) Inductive Reactive Energy III generated (kvarLh or MvarLh) Capacitive Reactive Energy III generated (kvarCh or MvarCh) Apparent Energy III generated (kVAh or MVAh)</p>

Operations	Parameters
	<p>No. of operations of stage C1 to C14 Three screens show the number of operations of the 14 possible stages.</p> <p> for more than 3 seconds: delete the no. of operations.</p>

This parameter should be associated with an alarm that is activated when the number of operations exceeds a pre-determined value (for example, 5000 operations) in order to perform the maintenance of this stage.

Active alarms	Parameters
	<p>Active alarm code E01 to E017 (Table 10)</p> <p>If there are more than 4 alarms, the information is scrolled on the screen.</p>

Table 10: Alarm codes.

Code	Description
<i>E01</i>	<p>No current. The load current is lower than the minimum value or some of the current transformers (CT) are not connected. It is activated when the secondary current of the transformer is lower than 50 mA in some of the phases. The device disconnects the capacitors automatically.</p>
<i>E02</i>	<p>Overcompensation. The device measures capacitive power but all the stages are disconnected. This can be due to an incorrect adjustment of the C/K parameter. In order to avoid possible false actions, this alarm has a predefined delay of 90 seconds.</p>
<i>E03</i>	<p>Undercompensation. The device measures inductive power but all the stages are connected. This can be due to an incorrect adjustment of the C/K parameter. In order to avoid possible false actions, this alarm has a predefined delay of 90 seconds.</p>
<i>E04</i>	<p>Overcurrent. The measured current exceeds the nominal current by + 20 % in some of the phases. The nominal current is considered to be that of the CT primary. In order to avoid possible false actions, this alarm has a predefined delay of 5 seconds.</p>
<i>E05</i>	<p>Overvoltage. The voltage measured in some of the phases exceeds the configured voltage (Vp-n). The device disconnects the capacitors automatically. In order to avoid possible false actions, this alarm has a predefined delay of 5 seconds.</p>
<i>E06</i>	<p>Low voltage. The voltage in some of the phases is lower than the configured voltage (Vp-n). The device disconnects the capacitors automatically. In order to avoid possible false actions, this alarm has a predefined delay of 5 seconds.</p>
<i>E07</i>	<p>Cos ϕ high or low alarm. The three-phase cos ϕ is outside the limits specified in one of the Cos ϕ alarms (high or low). Also, the measured currents should be higher than the configured threshold. In order to avoid possible false actions, this alarm has a predefined delay of 15 seconds.</p>
<i>E08*</i>	<p>Voltage THD Alarm. The Voltage THD levels in some of the phases are higher than those configured in the Voltage THD alarm.</p>
<i>E09*</i>	<p>Current x I THD Alarm. The IxITHD levels in some of the phases are higher than those configured in the IxITHD alarm. (IxITHD refers to the multiplication of the current by the ITHD of the same current, see "5.26. - CURRENT x I THD ALARM")</p>
<i>E10*</i>	<p>Temperature Alarm. The measured temperature is higher than that configured in the Temperature alarm.</p>
<i>E11</i>	<p>No Connection Status due to <i>E08</i>, <i>E09</i> or <i>E10</i>.</p>

Table 10 (Continuation): Alarm codes.

Code	Description
<i>E12</i>	Disconnection Status due to <i>E08</i> , <i>E09</i> or <i>E10</i> .
<i>E13</i>	Leakage Alarm. The leakage current is higher than that configured in the Leakage Current alarm.
<i>E14</i>	Repeated Leakage Alarm. Leakages have been detected repeatedly in the system, but they are not caused by a capacitor.
<i>E15</i>	Leakage in Capacitors Alarm. Leakages have been detected, which were caused by some of the capacitors, and this stage is disabled. The disabled capacitors will start to flash on the screen. In addition, the <i>E13</i> message will be displayed. In order to enable these capacitors again, view the configuration of the Leakage alarm.
<i>E16</i>	Leakage transformer detection Alarm. The Leakage alarm has been enabled, but the device does not detect the connection of the leakage current transformer.
<i>E17</i>	Number of connections alarm. The configured number of operations has been exceeded (any capacitor)

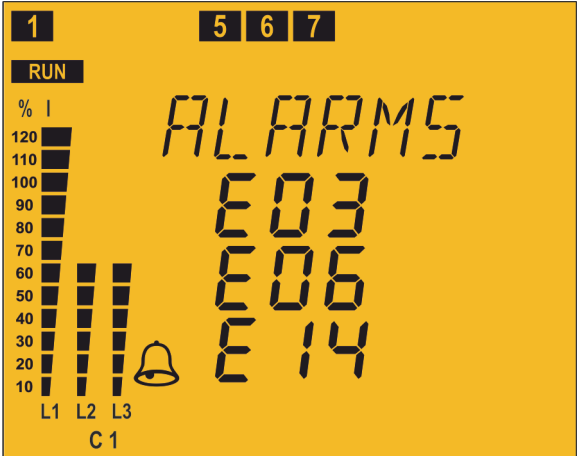
* In these alarms, two levels have been configured:

✓ The **Lo value**: When the device exceeds this value during 30 minutes, the corresponding alarm is triggered and, if alarm *E11* is enabled, the **Computer SMART III** device enters the **No Connection** status and activates alarm *E11*.

✓ The **Hi value**: if the device exceeds this value during 30 seconds, the corresponding alarm is triggered and, if alarm *E12* is enabled, the **Computer SMART III** device enters the **Disconnection** status and activates alarm *E12*.

If the device falls back under the Lo value during 10 minutes, it deactivates the alarms and returns to the normal operating status.

In the **No Connection** status, the device does not connect the stages, but also does not disconnect them if the operation requires it.

In the **Disconnection** status, it disconnects the stages and does not allow them to connect.

4.6.1.2. 3U. 1C Connection (3 Voltages + Neutral and 1 current)

Main Screen	Parameters
	<p>Active Power III (kW or MW) Reactive Power III(kvar or Mvar) +: inductive / -: capacitive Cos φ L: Inductive / C: capacitive +: consumed / -: generated Phase - Phase Voltage III(V or kV)</p> <p>◀ Display the minimum values. ▶ Display the maximum values.</p>

Press the key to switch to the Currents screen.

Phase - Neutral Voltages	Parameters
	<p>L1 Phase - Neutral Voltage (V or kV) L2 Phase - Neutral Voltage (V or kV) L3 Phase - Neutral Voltage (V or kV) Phase - Neutral Voltage III(V or kV)</p> <p>◀ Display the minimum values. ▶ Display the maximum values.</p>

Phase - Phase Voltages	Parameters
	<p>L1 Phase - Phase Voltage (V or kV) L2 Phase - Phase Voltage (V or kV) L3 Phase - Phase Voltage (V or kV) Phase - Phase Voltage III(V or kV)</p> <p>◀ Display the minimum values. ▶ Display the maximum values.</p>

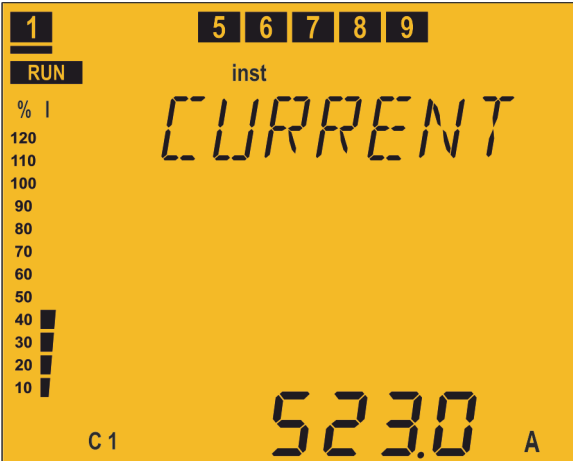
Currents	Parameters
	<p>Current (A)</p> <p> <input type="checkbox"/> Display the minimum values. <input type="checkbox"/> Display the maximum values. </p>

Press the  or  key to switch to the Cosine φ screen.

Cosine φ	Parameters
	<p>Cos φ L: Inductive / C: capacitive +: consumed / -: generated</p> <p> <input type="checkbox"/> Display the minimum values. <input type="checkbox"/> Display the maximum values. </p>

Press the  key to switch to the Energy III consumed screen.

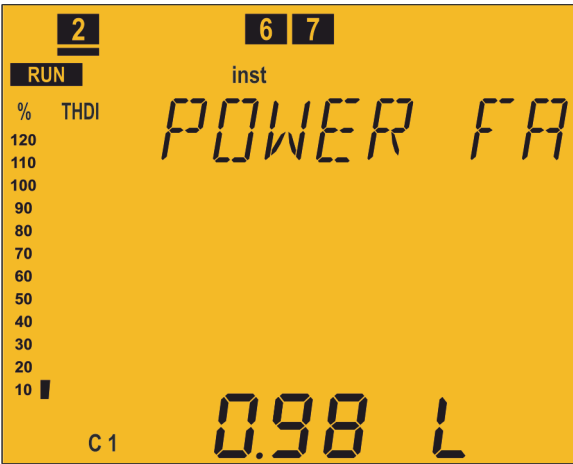
Power Factor	Parameters
	<p>Power factor L: Inductive / C: capacitive +: consumed / -: generated</p> <p> <input type="checkbox"/> Display the minimum values. <input type="checkbox"/> Display the maximum values. </p>

Power III	Parameters
<p>The screenshot shows a yellow background with a vertical scale on the left from 10 to 120. At the top, there are three buttons labeled 7, 8, and 9. Below them is a 'RUN' button and the text 'inst'. The main display shows 'POWER III' in large letters. Below that, four numerical values are displayed: 35.54 kW, 6.28 kvarL, 0.00 kvarC, and 36.13 kVA. On the left side, there are three bar graphs labeled L1, L2, and L3, and a 'C 1' label at the bottom.</p>	<p>Active Power III(kW or MW) Inductive Reactive Power III (kvarL or MvarL) Capacitive Reactive Power III (kvarC or MvarC) Apparent Power III (kVA or MVA)</p> <p>◀ Display the minimum values. ▶ Display the maximum values.</p>

Leakage current / Frequency / Temperature	Parameters
<p>The screenshot shows a yellow background with a vertical scale on the left from 10 to 120. At the top, there are two buttons labeled 1 and 2. Below them is a 'RUN' button and the text 'inst'. The main display shows 'I LEAK / F' in large letters. Below that, three numerical values are displayed: 30 mA, 50.0 Hz, and 35.8 °C. On the left side, there are three bar graphs labeled L1, L2, and L3, and a 'C 1' label at the bottom.</p>	<p>Leakage current (mA) Frequency (Hz) Temperature (°C)</p> <p>◀ Display the minimum values. ▶ Display the maximum values.</p>

Voltage THD	Parameters
<p>The screenshot shows a yellow background with a vertical scale on the left from 10 to 120. At the top, there are three buttons labeled 1, 2, and 3. Below them is a 'RUN' button and the text 'inst'. The main display shows 'THD U %' in large letters. Below that, three numerical values are displayed: 18% THDU for L1, 15% THDU for L2, and 16% THDU for L3. On the left side, there are three bar graphs labeled L1, L2, and L3, and a 'C 1' label at the bottom.</p>	<p>L1 Voltage THD L2 Voltage THD L3 Voltage THD (%)</p> <p>▶ Display the maximum values.</p>

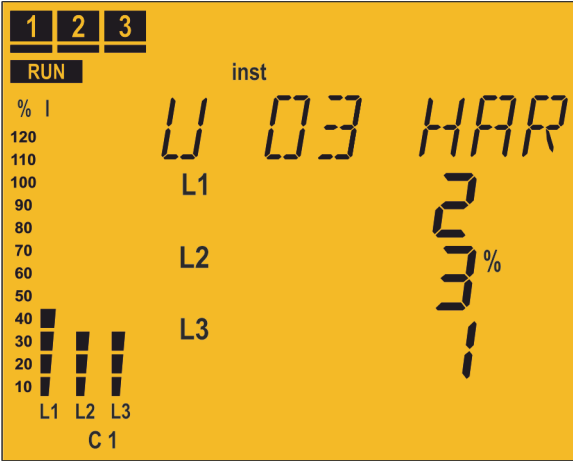
Voltage harmonics	Parameters
 <p>The screenshot shows a yellow background with a vertical scale on the left from 10 to 120. At the top, there are three buttons labeled '1', '2', and '3'. Below them is a 'RUN' indicator. The main display shows 'U 03 HARM' and '23%' with a large '2' and '3' stacked vertically. Labels 'L1', 'L2', and 'L3' are positioned below the scale. A 'C 1' label is at the bottom.</p>	<p>L1 Voltage harmonic L2 Voltage harmonic L3 Voltage harmonic (%)</p> <p>☰ Change the harmonic no.: 3, 5, 7, 9, 11, 13, 15, 17.</p> <p>➤ Display the maximum values.</p>

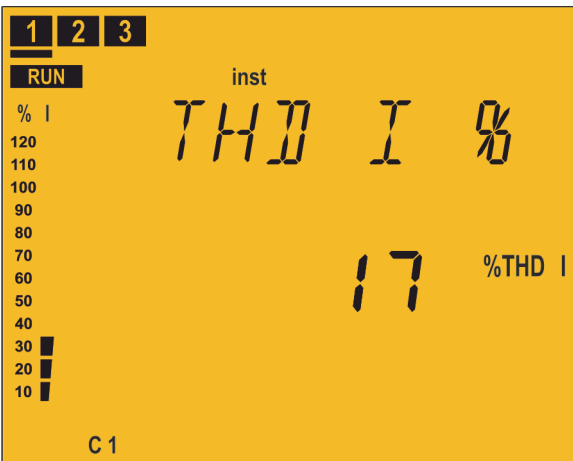
Current THD	Parameters
 <p>The screenshot shows a yellow background with a vertical scale on the left from 10 to 120. At the top, there are three buttons labeled '1', '2', and '3'. Below them is a 'RUN' indicator. The main display shows 'THD I %' and '17 %THD I'. A 'C 1' label is at the bottom.</p>	<p>Current THD (%)</p> <p>➤ Display the maximum values.</p>

Current harmonics	Parameters
 <p>The screenshot shows a yellow background with a vertical scale on the left from 10 to 120. At the top, there are three buttons labeled '1', '2', and '3'. Below them is a 'RUN' indicator. The main display shows 'I 03 HARM' and '28%'. A 'C 1' label is at the bottom.</p>	<p>Current harmonic (%)</p> <p>☰ Change the harmonic no.: 3, 5, 7, 9, 11, 13, 15, 17.</p> <p>➤ Display the maximum values.</p>

Energy III consumed	Parameters
	<p>Active Energy III consumed (kWh or MWh)</p> <p>Inductive Reactive Energy III consumed (kvarLh or MvarLh)</p> <p>Capacitive Reactive Energy III consumed (kvarCh or MvarCh)</p> <p>Apparent Energy III consumed (kVAh or MVAh)</p>

Press the key to switch to the **Main** screen.



Energy III generated	Parameters
	<p>Active Energy III generated (kWh or MWh)</p> <p>Inductive Reactive Energy III generated (kvarLh or MvarLh)</p> <p>Capacitive Reactive Energy III generated (kvarCh or MvarCh)</p> <p>Apparent Energy III generated (kVAh or MVAh)</p>

Operations	Parameters
	<p>No. of operations of stage C1 to C14 Three screens show the number of operations of the 14 possible stages.</p> <p> for more than 3 seconds: delete the no. of operations.</p>

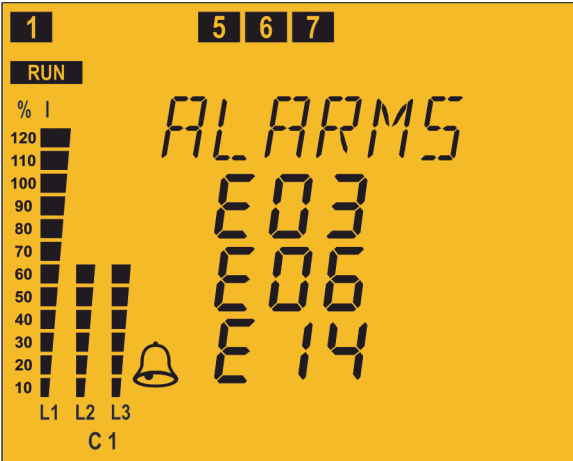

This parameter should be associated with an alarm that is activated when the number of operations exceeds a pre-determined value (for example, 5000 operations) in order to perform the maintenance of this stage.

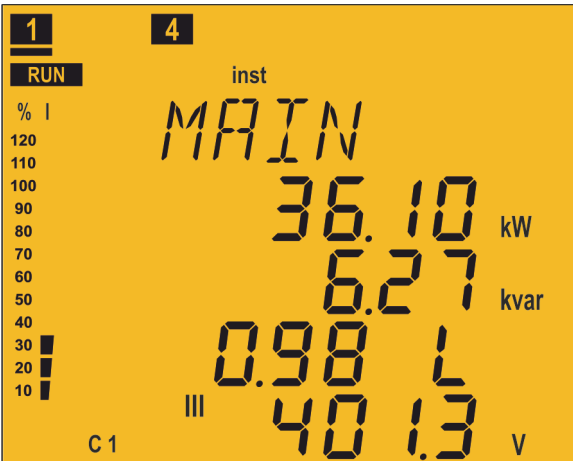
Active alarms	Parameters
	<p>Active alarm code E01 to E017 (Table 10). If there are more than 4 alarms, the information is scrolled on the screen.</p>

4.6.1.3. 2U. I_C Connection (2 Voltages and 1 current)

Main Screen	Parameters
	<p>Active Power III (kW or MW) Reactive Power III(kvar or Mvar) +: inductive / -: capacitive Cos φ L: Inductive / C: capacitive +: consumed / -: generated Phase - Phase Voltage (V or kV)</p> <p> Display the minimum values.  Display the maximum values.</p>

Press the  key to switch to the **Currents** screen.

Phase - Phase Voltages	Parameters
	<p>Phase - Phase Voltage (V or kV)</p> <p> Display the minimum values.  Display the maximum values.</p>

Currents	Parameters
	<p>Current (A)</p> <p> Display the minimum values.</p> <p> Display the maximum values.</p>

Press the or key to switch to the Cosine ϕ screen.

Cosine ϕ	Parameters
	<p>Cos ϕ L: Inductive / C: capacitive +: consumed / -: generated</p> <p> Display the minimum values.</p> <p> Display the maximum values.</p>

Press the key to switch to the Energy III consumed screen.

Power Factor	Parameters
	<p>Power factor L: Inductive / C: capacitive +: consumed / -: generated</p> <p> Display the minimum values.</p> <p> Display the maximum values.</p>

Power III	Parameters
	<p>Active Power III(kW or MW) Inductive Reactive Power III (kvarL or MvarL) Capacitive Reactive Power III (kvarC or MvarC) Apparent Power III (kVA or MVA)</p> <p>◀ Display the minimum values. ▶ Display the maximum values.</p>

Leakage current / Frequency / Temperature	Parameters
	<p>Leakage current (mA) Frequency (Hz) Temperature (°C)</p> <p>◀ Display the minimum values. ▶ Display the maximum values.</p>

Voltage THD	Parameters
	<p>Voltage THD (%)</p> <p>▶ Display the maximum values.</p>

Voltage harmonics	Parameters
	<p>Voltage harmonic (%)</p> <ul style="list-style-type: none"> Change the harmonic no.: 3, 5, 7, 9, 11, 13, 15, 17. Display the maximum values.

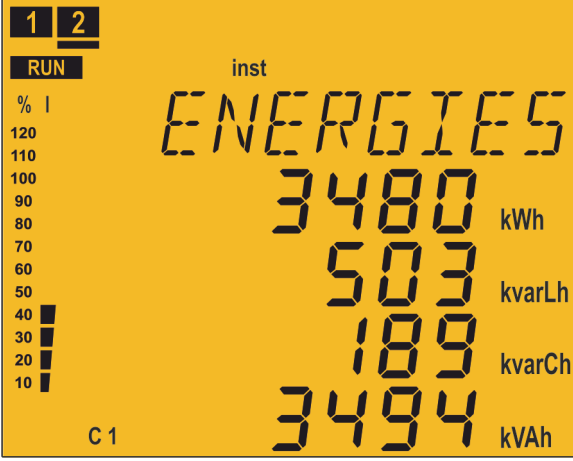

Current THD	Parameters
	<p>Current THD (%)</p> <ul style="list-style-type: none"> Display the maximum values.

Current harmonics	Parameters
	<p>Current harmonic (%)</p> <ul style="list-style-type: none"> Change the harmonic no.: 3, 5, 7, 9, 11, 13, 15, 17. Display the maximum values.

Energy III consumed	Parameters
	<p>Active Energy III consumed (kWh or MWh)</p> <p>Inductive Reactive Energy III consumed (kvarLh or MvarLh)</p> <p>Capacitive Reactive Energy III consumed (kvarCh or MvarCh)</p> <p>Apparent Energy III consumed (kVAh or MVAh)</p>

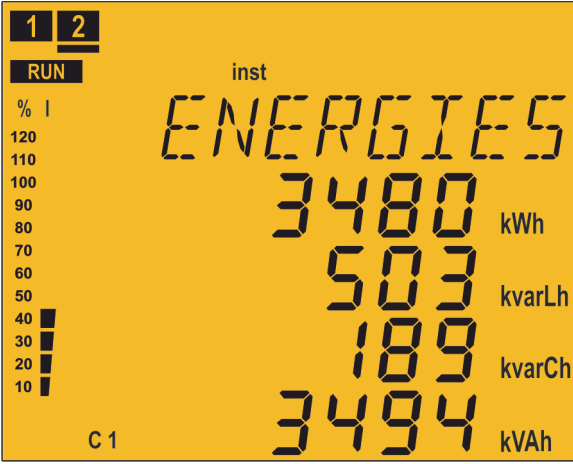
Press the  key to switch to the **Main** screen.

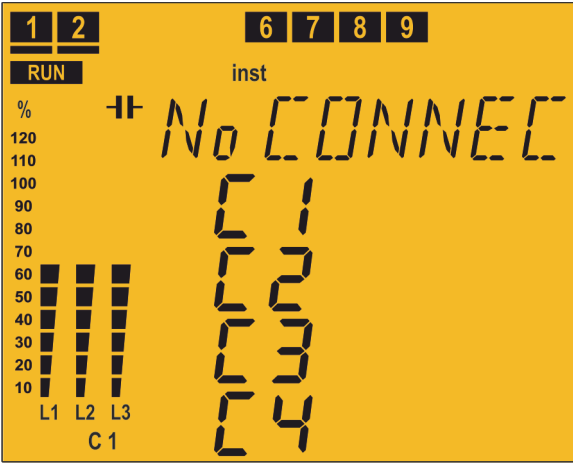
Energy III generated	Parameters
	<p>Active Energy III generated (kWh or MWh)</p> <p>Inductive Reactive Energy III generated (kvarLh or MvarLh)</p> <p>Capacitive Reactive Energy III generated (kvarCh or MvarCh)</p> <p>Apparent Energy III generated (kVAh or MVAh)</p>

Operations	Parameters
	<p>No. of operations of stage C1 to C14 Three screens show the number of operations of the 14 possible stages.</p> <p> for more than 3 seconds: delete the no. of operations.</p>

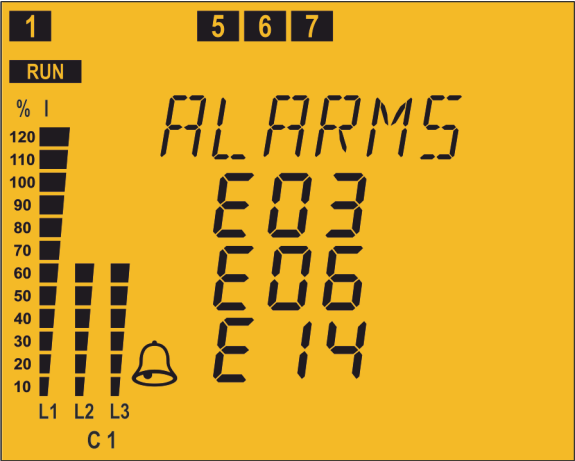

This parameter should be associated with an alarm that is activated when the number of operations exceeds a pre-determined value (for example, 5000 operations) in order to perform the maintenance of this stage.



Active alarms	Parameters
	<p>Active alarm code E01 to E017 (Table 10)</p> <p>If there are more than 4 alarms, the information is scrolled on the screen.</p>

4.6.2. TEST STATUS

This status is identified by the **TEST** symbol in the device status area of the display (Figure 15).

The stages can be connected and disconnected manually, and the measured parameters that relate to each one of the stages can be displayed. It also comprises the AutoTest function, which scans and calculates all the stages of the device.





A very long keystroke (> 10s) of the   key in any of the measurement screens causes the device to enter the Test status.

A very long keystroke (> 10s) of the   key in any of the Test screens causes the device to return to the Measurement status.



Use keys  and  to browse the various screens.



If 5 minutes pass without any keys being pressed, the device returns to the main screen.



Disconnection screen	Parameters
	<p>Transition screen: used for the device to disconnect all the stages automatically before entering the Test status.</p> <p>While in this screen, the device does not respond to the keypad.</p> <p>The device automatically exits this screen, and this can take a certain amount of time.</p>

AutoTest	Parameters
	<p>AutoTest home screen.</p> <p>To start the AutoTest: Press the  key, <i>OFF</i> flashes. Press the  key to switch from <i>OFF</i> to <i>Start</i> Press the  key to start the AutoTest</p>
	<p>Once the AutoTest has started, the results of the capacitors that are connected and disconnected are shown:</p> <p>Leakage current (mA) Capacitive Reactive Power (kvarC or MvarC) Capacitive Power % of each capacitor relative to the total estimated value.</p> <p>The RUN icon flashes during the AutoTest.</p>

A long keystroke (> 3 s) of the  key cancels the AutoTest.
 At the end of the AutoTest, the device automatically returns to the Individual Test screen.

Step Test	Parameters
	<p>Leakage current (mA) Capacitive Reactive Power (kvarC or MvarC) Capacitive Power % of each capacitor relative to the total estimated value.</p> <p>  Switches between the various capacitors.</p>

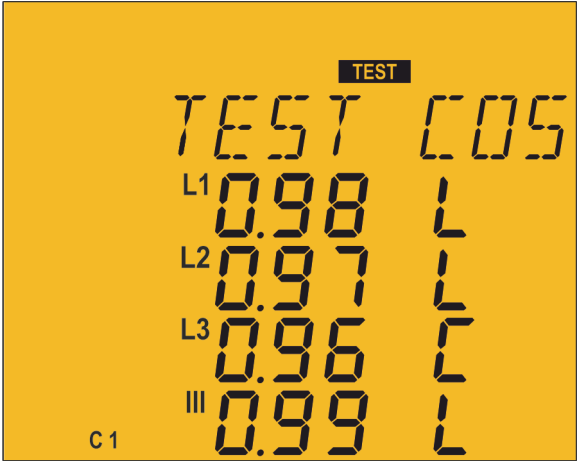
A long keystroke (> 3 s) of the  key connects the capacitor that is being displayed, taking into account the programmed connection and reclosing times.
 A long keystroke (> 3 s) of the  key disconnects the capacitor that is being displayed, taking into account the programmed connection and reclosing times.

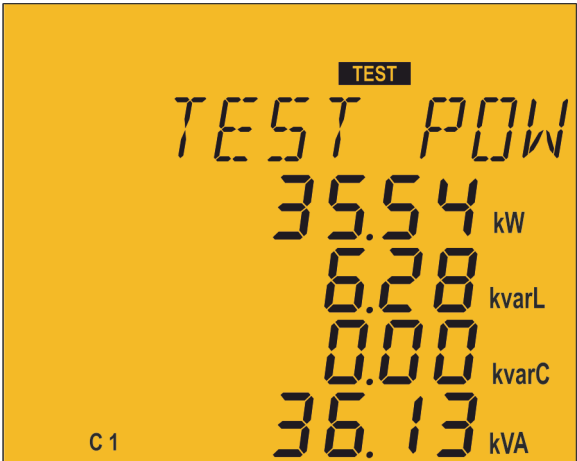
Cosine ϕ Test	Parameters
	<p>Display screen of the: Cos ϕ (2U. 1C and 3U. 1C connection)</p> <p>L1 Cos ϕ (3U.3C connection) L2 Cos ϕ (3U.3C connection) L3 Cos ϕ (3U.3C connection) Cos ϕ III (3U.3C connection)</p> <p>L: Inductive / C: capacitive +: consumed / -: generated</p>
Current THD Test	Parameters
	<p>Display screen of the: Current THD (2U. 1C and 3U. 1C connection)</p> <p>L1 Current THD (3U.3C connection) L2 Current THD (3U.3C connection) L3 Current THD (3U.3C connection)</p>
Power III Test	Parameters
	<p>Display screen of the:</p> <p>Active Power III(kW or MW) Inductive Reactive Power III (kvarL or MvarL) Capacitive Reactive Power III (kvarC or MvarC) Apparent Power III (kVA or MVA)</p>

4.7.- INPUTS

The **Computer SMART III** comprises two digital inputs (terminals 31 and 32 of **Figure 2**) for activating any of the four **target cos φ** , in other words, the desired power factor for the installation, which can be programmed in the device. See **"5.3.- TARGET COS φ "**

Table 11: Selection of the target cos φ .

Digital input 2	Digital Input 1	Target cos φ
0	0	1
0	1	2
1	0	3
1	1	4

On the display, the **C 1234** icon indicates which of the four possible target cosines was selected.

4.8.- OUTPUTS

The device features:

- ✓ A relay (terminals 37 and 38 of **Figure 2**) dedicated to activating a fan when a pre-determined temperature is exceeded, which can be programmed in **"5.17.- FAN"**, also connected to the **Fan LED**.

- ✓ A fully programmable alarm relay (terminals 39, 40 and 41 of **Figure 2**); see **"5.21.- ENABLING ALARMS"**

- ✓ Two digital outputs, optoisolated NPN transistors (terminals 34, 35 and 36 of **Figure 2**), fully programmable; see **"5.21.- ENABLING ALARMS"**.

Computer SMART III 6 model:

- ✓ Six output relays (terminals 15 to 21 of **Figure 2**) for regulating the cos φ by means of capacitors.

Computer SMART III 12 model:

- ✓ Twelve output relays (terminals 15 to 27 of **Figure 2**) for regulating the cos φ by means of capacitors.

Computer SMART III 14 model:

- ✓ Fourteen output relays (terminals 15 to 27 and 42 to 44 of **Figure 2**) for regulating the cos φ by means of capacitors.

4.9.- COMMUNICATIONS

Computer SMART III devices have an RS-485 serial communication output with the Modbus RTU[®] communications protocol.

4.9.1. CONNECTIONS

The RS-485 cable should be wired with a twisted pair cable with mesh shield (minimum 3 wires), with a maximum distance between the Computer SMART III and the master device of 1200 metres. A maximum of 32 Computer SMART III devices can be connected to this bus.

Use an intelligent RS-232 to RS-485 network protocol converter (M54020 intelligent converter) to establish the communications with the master device. This converter does away with the need for the Pin 7 connection on the RS-485 side.

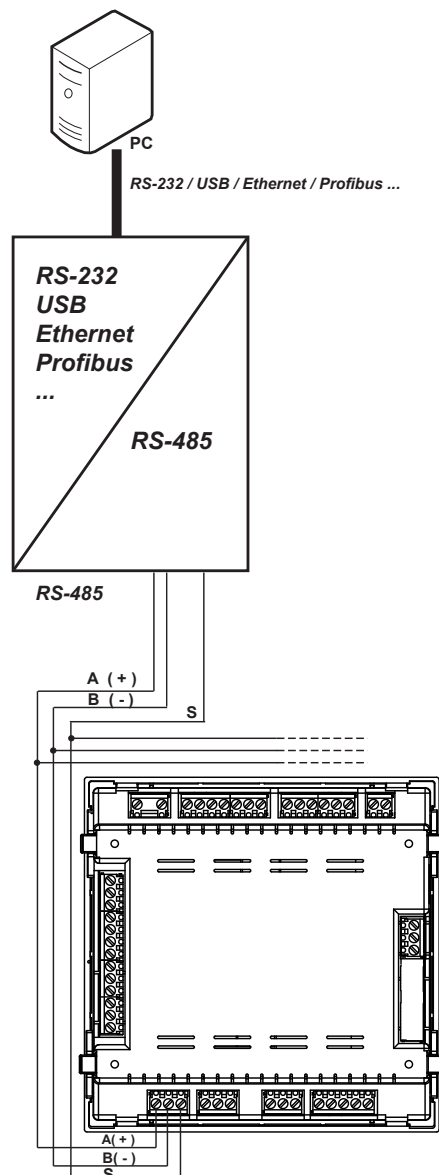

Figure 19: RS-485 Connection diagram

4.9.2. PROTOCOL

The Modbus protocol is an industry communication standard which enables networking of multiple devices, with one master and several slaves. It allows individual master-slave dialogue and also enables commands in broadcast format.

In the Modbus protocol, the **Computer SMART III** device uses the RTU (Remote Terminal Unit) mode.

In the RTU mode, the message start and end are detected with silences of at least 3.5 characters, and the 16-bit CRC error-detection method is used.

The Modbus functions implemented in the device are as follows:

Function 01. Reading the status of the relays.

Functions 03 and 04. Reading logs.

Function 05. Writing a relay.

Function 0F. Writing multiple relays.

Function 10. Writing multiple logs.

Exception codes

If the bit with greatest weight of the byte corresponding to the function in the reply of the device is 1, this indicates that the next byte is an exception code.

Table 12: Exception codes, Modbus communications.

Exception code	Description
01	Incorrect function. The function number is not implemented.
02	Incorrect address or number of logs out of limits
03	Data error. A CRC error has occurred
04	Peripheral error. An error occurred when accessing a peripheral (EEPROM, card, etc.)
06	Slave error or Slave busy. Retry sending.

Example:

Address	Function	Exception code	CRC
0A	84	01	XXXX

Address: 0A, Peripheral number: 10 in decimal.

Function: 84, Reading function 04 with bit no. 7 at 1.

Exception code: 01, see **Table 10**.

CRC: 16-bit CRC.



For reasons of operational security of the device, communication frames of more than 80 bytes are not accepted (sent or received).

4.9.3. MODBUS MEMORY MAP

A.- Measurement Variables

For these variables **Function 04** is implemented: reading logs.
The Modbus addresses of all the tables are hexadecimal.

Table 13: Modbus memory map: measurement variables (Table 1)

Parameter	Instantaneous	Maximum	Minimum	Units
L1 phase voltage	00-01	200-201	300-301	V/100
L1 Current	02-03	202-203	302-303	mA
L1 Active Power	04-05	204-205	304-305	W
L1 Inductive Reactive Power	06-07	206-207	306-307	varL
L1 Capacitive Reactive Power	08-09	208-209	308-309	varC
L1 Reactive Power	0A-0B	20A-20B	30A-30B	var
L1 Apparent Power	0C-0D	20C-20D	30C-30D	VA
L1 Reactive Power Consumed	0E-0F	20E-20F	30E-30F	var
L1 Reactive Power Generated	10-11	210-211	310-311	var
L1 Power Factor ⁽⁷⁾	12-13	212-213	312-313	-
L1 Cos φ ⁽⁷⁾	14-15	214-215	314-315	-
L1 kW sign ⁽⁷⁾	16-17	-	-	+1 or -1
L1 kvar sign ⁽⁷⁾	18-19	-	-	+1 or -1
L2 phase voltage	1A-1B	21A-21B	31A-31B	V/100
L2 Current	1C-1D	21C-21D	31C-31D	mA
L2 Active Power	1E-1F	21E-21F	31E-31F	W
L2 Inductive Reactive Power	20-21	220-221	320-321	varL
L2 Capacitive Reactive Power	22-23	222-223	322-323	varC
L2 Reactive Power	24-25	224-225	324-325	var
L2 Apparent Power	26-27	226-227	326-327	VA
L2 Reactive Power Consumed	28-29	228-229	328-329	var
L2 Reactive Power Generated	2A-2B	22A-22B	32A-32B	var
L2 Power Factor ⁽⁷⁾	2C-2D	22C-22D	32C-32D	-
L2 Cos φ ⁽⁷⁾	2E-2F	22E-22F	32E-32F	-
L2 kW sign ⁽⁷⁾	30-31	-	-	+1 or -1
L2 kvar sign ⁽⁷⁾	32-33	-	-	+1 or -1
L3 phase voltage	34-35	234-235	334-335	V/100
L3 Current	36-37	236-237	336-337	mA
L3 Active Power	38-39	238-239	338-339	W
L3 Inductive Reactive Power	3A-3B	23A-23B	33A-33B	varL
L3 Capacitive Reactive Power	3C-3D	23C-23D	33C-33D	varC
L3 Reactive Power	3E-3F	23E-23F	33E-33F	var
L3 Apparent Power	40-41	240-241	340-341	VA
L3 Reactive Power Consumed	42-43	242-243	342-343	var
L3 Reactive Power Generated	44-45	244-245	344-345	var
L3 Power Factor ⁽⁷⁾	46-47	246-247	346-347	-
L3 Cos φ ⁽⁷⁾	48-49	248-249	348-349	-
L3 kW sign ⁽⁷⁾	4A-4B	-	-	+1 or -1

Table 13 (Continuation): Modbus memory map: measurement variables (Table 1)

Parameter	Instantaneous	Maximum	Minimum	Units
L3 kvar sign ⁽⁷⁾	4C-4D	-	-	+1 or -1
Three-phase phase voltage	4E-4F	24E-24F	34E-34F	V/100
Three-phase current	50-51	250-251	350-351	mA
Three-phase active power	52-53	252-253	352-353	W
Three-phase inductive power	54-55	254-255	354-355	varL
Three-phase capacitive power	56-57	256-257	356-357	varC
Three-phase reactive power	58-59	258-259	358-359	var
Three-phase apparent power	5A-5B	25A-25B	35A-35B	VA
Three-phase reactive power consumed	5C-5D	25C-25D	35C-35D	var
Three-phase reactive power generated	5E-5F	25E-25F	35E-35F	var
Three-phase power factor ⁽⁷⁾	60-61	260-261	360-361	-
Three-phase cos φ ⁽⁷⁾	62-63	262-263	362-363	-
Three-phase kW sign ⁽⁷⁾	64-65	-	-	-
Three-phase kvar sign ⁽⁷⁾	66-67	-	-	-
Frequency	68-69	268-269	368-369	Hz/10
L1-L2 Voltage	6A-6B	26A-26B	36A-36B	V/100
L2-L3 Voltage	6C-6D	26C-26D	36C-36D	V/100
L3-L1 Voltage	6E-6F	26E-26F	36E-36F	V/100
Neutral Current	70-71	270-271	370-371	mA
Leakage Current	72-73	272-273	372-373	mA
Temperature	74-75	274-275	374-375	°C/10
L1 voltage THD %	7C-7D	27C-27D	-	%
L2 voltage THD %	7E-7F	27E-27F	-	%
L3 voltage THD %	80-81	280-281	-	%
L1 current THD %	82-83	282-283	-	%
L2 current THD %	84-85	284-285	-	%
L3 current THD %	86-87	286-287	-	%
Active energy consumed kWh	88-89	-	-	kWh
Active energy consumed Wh	8A-8B	-	-	Wh
Inductive energy consumed kvarLh	8C-8D	-	-	kvarLh
Inductive energy consumed varLh	8E-8F	-	-	varLh
Capacitive energy consumed kvarCh	90-91	-	-	kvarCh
Capacitive energy consumed varCh	92-93	-	-	varCh
Apparent energy consumed kVAh	94-95	-	-	kVAh
Apparent energy consumed VAh	96-97	-	-	VAh
Active energy generated kWh	98-99	--	-	kWh
Active energy generated Wh	9A-9B	-	-	Wh
Inductive energy generated kvarLh	9C-9D	-	-	kvarLh
Inductive energy generated varLh	9E-9F	-	-	varLh
Capacitive energy generated kvarCh	A0-A1	-	-	kvarCh
Capacitive energy generated varCh	A2-A3	-	-	varCh
Apparent energy generated kVAh	A4-A5	-	-	kVAh
Apparent energy generated VAh	A6-A7	-	-	VAh

⁽⁷⁾ The **cos φ** and **Power factor** parameters are accompanied by the **kW sign** and **kva sign** parameters, which are used to determine the quadrant in which each phase is being measured. See **Figure 20**.

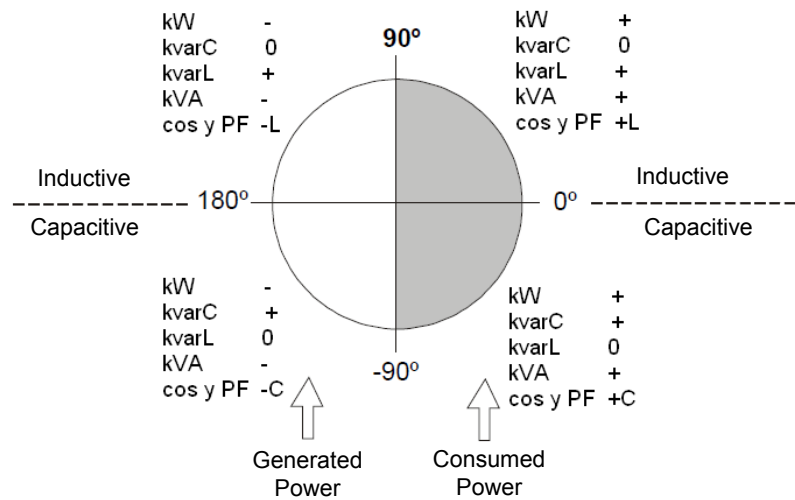

Figure 20: Diagram of the four measurement and compensation quadrants.

Table 14: Modbus memory map: measurement variables (Table 2)

Parameter	Instantaneous	Maximum	Units
L1 Fundamental Voltage Harmonic	400-401	484-485	V/100
L1 Voltage Harmonics	402-415	486-499	% / 10
L2 Fundamental Voltage Harmonic	416-417	49A-49B	V/100
L2 Voltage Harmonics	418-42B	49C-4AF	% / 10
L3 Fundamental Voltage Harmonic	42C-42D	4B0-4B1	V/100
L3 Voltage Harmonics	42E-441	4B2-4C5	% / 10
L1 Fundamental Current Harmonic	442-443	4C6-4C7	mA
L1 Current Harmonics	444-457	4C8-4DB	% / 10
L2 Fundamental Current Harmonic	458-459	4DC-4DD	mA
L2 Current Harmonics	45A-46D	4DE-4F1	% / 10
L3 Fundamental Current Harmonic	46E-46F	4F2-4F3	mA
L3 Current Harmonics	470-483	4F4-507	% / 10

Table 15: Modbus memory map: measurement variables (Table 3)

Parameter	Instantaneous
Relay variable	600
Alarm variable	605-606
Status of the outputs	610
Status of the digital inputs	615
No. of connections, of each of the 14 relays (6 in the Computer SMART III 6 model, 12 in the Computer SMART III 12 model,)	625-63E

✓ **Relay variable**

Shows the status of the 14 (**Computer SMART III 14** model), 12 (**Computer SMART III 12** model) or 6 (**Computer SMART III 6** model) output relays.

It is a 16-bit variable in which each bit indicates the status of a relay.

	Bit 15-14	Bit 13	Bit 12	Bit 11	Bit 10	Bit 9	Bit 8	Bit 7	Bit 6	Bit 5	Bit 4	Bit 3	Bit 2	Bit 1	Bit 0
Relay	-	14	13	12	11	10	9	8	7	6	5	4	3	2	1

Where 0: relay disconnected (OFF).

1: relay connected (ON).

✓ **Alarm Variable**

Shows the status of the 17 possible alarms.

It is a 32-bit variable in which each bit indicates the status of an alarm.

Bit 15	Bit 14	Bit 13	Bit 12	Bit 11	Bit 10	Bit 9	Bit 8	Bit 7	Bit 6	Bit 5	Bit 4	Bit 3	Bit 2	Bit 1	Bit 0
E16	E15	E14	E13	E12	E11	E10	E09	E08	E07	E06	E05	E04	E03	E02	E01

Bit 32	Bit 31	Bit 30	Bit 29	Bit 28	Bit 27	Bit 26	Bit 25	Bit 24	Bit 23	Bit 22	Bit 21	Bit 20	Bit 19	Bit 18	Bit 16
-	-	-	-	-	-	-	-	-	-	-	-	-	-	-	E17

Where 0: alarm off (OFF).

1: alarm active (ON).

✓ **Status of the outputs**

Shows the status of the 4 outputs: Fan relay, alarm relay and the two digital outputs.

It is a 16-bit variable in which each bit indicates the status of an output.

Bit 15 to 4	Bit 3	Bit 2	Bit 1	Bit 0
-	Digital output 2	Digital output 1	Alarm relay	Fan relay
-	1: OFF 0: ON	1: OFF 0: ON	1: ON 0: OFF	1: ON 0: OFF

✓ **Status of the digital inputs**

Shows the status of the 2 digital inputs.

It is a 16-bit variable in which each bit indicates the status of an input.

Bit 15 to 2	Bit 1	Bit 0
-	Digital input 2	Digital input 1
-	1: ON 0: OFF	1: ON 0: OFF

B.- Programming variables

The following functions are implemented for these variables:

Function 04: reading logs.

Function 10: Writing multiple logs.

Table 16: Modbus memory map: programming variables (Table 1)

Device parameters	
Configuration variable	Address
Serial number ⁽⁸⁾	1000-1003
Frame number ⁽⁸⁾	1010-1013
Version ⁽⁸⁾	1020-1021
Hardware log ⁽⁸⁾	1030-1033

⁽⁸⁾ The parameters of the device have only implemented **function 04**.

Table 17: Modbus memory map: programming variables (Table 2)

Communications			
Configuration variable	Address	Valid data window	Default value
Peripheral no.	1071	1 to 254	1
Speed	1072	0 (9600), 1 (19200)	1
Parity	1073	0 (none), 1 (odd), 2 (even)	0
Length	1074	0 (8 bits), 1 (7 bits)	0
Stop bits	1075	0 (1 bits), 1 (2 bits)	0

Table 18: Modbus memory map: programming variables (Table 3)

Transformation ratios			
Configuration variable	Address	Valid data window	Default value
Current primary	1090	1 - 10000	5
Current secondary	1091	0 (1 A), 1 (5 A)	1
Voltage primary	1095-1096	1 - 99999	400
Voltage secondary	1097-1098	1 - 99999	400

Table 19: Modbus memory map: programming variables (Table 4)

Connection type			
Configuration variable	Address	Valid data window	Default value
Connection type	1100	0 (3U.3C), 1 (3U.1C), 2 (2U.1C)	0
Phase ⁽⁹⁾	1101	1 to 6 (Table 42)	1
Current 1 ⁽⁹⁾⁽¹⁰⁾	1102	1 (Phase 1 direct), 2 (Phase 2 direct), 3 (Phase 3 direct), 4 (Phase 1 reverse), 5 (Phase 2 reverse), 6 (Phase 3 reverse),	1
Current 2 ⁽⁹⁾⁽¹⁰⁾	1103		2
Current 3 ⁽⁹⁾⁽¹⁰⁾	1104		3

⁽⁹⁾ Only used when the connection type is other than 3U.3C.

⁽¹⁰⁾ Indicates the relationship between the assigned voltage and the current direction.

Example: If you see Current 1 = 1, Current 2 = 5 and Current 3 = 3, this means that:

Current 1 is assigned to voltage 1 in the direct direction, current 2 is assigned to voltage 2 in the reverse direction and current 3 is assigned to voltage 3 in the direct direction.

Table 20: Modbus memory map: programming variables (Table 5)

Status of the stages			
Configuration variable	Address	Valid data window	Default value
C1	1110	0 (Auto), 1 (On), 2 (OFF), 3 (OnNc)	0
C2	1111		0
C3	1112		0
C4	1113		0
C5	1114		0
C6	1115		0
C7	1116		0
C8	1117		0
C9	1118		0
C10	1119		0
C11	111A		0
C12	111B		0
C13	111C		0
C14	111D		0

Table 21: Modbus memory map: programming variables (Table 6)

Voltage level			
Configuration variable	Address	Valid data window	Default value
Voltage level	1121	0 (Low voltage) 1 (Medium/High voltage)	0

Table 22: Modbus memory map: programming variables (Table 7)

Display			
Configuration variable	Address	Valid data window	Default value
Lighting (Backlight)	1125	0 (Comes on when pressing a key) 1 (ON), 2 (OFF)	0
Light level	1126	0 -10 (Value % / 10)	7
Language	1127	0 (Spanish), 1 (English), 2 (French), 3 (Turkish)	0
Advanced setup	1128	0 (OFF), 1 (ON)	0
Analogue bar	1129	0 (No), 1 (Current), 2 (ITHD) 3 (Connected power)	0

Table 23: Modbus memory map: programming variables (Table 8)

Target cos φ			
Configuration variable	Address	Valid data window	Default value
Target cos φ 1	1130	50 - 100 (Value x 100)	100
Target cos φ 2	1131		100
Target cos φ 3	1132		100
Target cos φ 4	1133		100
Target cos φ 1 type	1134	0 (Capacitive) 1 (Inductive)	1
Target cos φ 2 type	1135		1
Target cos φ 3 type	1136		1
Target cos φ 4 type	1137		1

Table 24: Modbus memory map: programming variables (Table 9)

Capacitive and Inductive Hysteresis			
Configuration variable	Address	Valid data window	Default value
Capacitive hysteresis	1185	0 - 10 (Value x 100)	0
Inductive hysteresis	1186		

Table 25: Modbus memory map: programming variables (Table 10)

C/K factor			
Configuration variable	Address	Valid data window	Default value
C/K factor	1138	0 - 100 (Value x 100)	100

Table 26: Modbus memory map: programming variables (Table 11)

Program			
Configuration variable	Address	Valid data window	Default value
Program	1139	1111-1999	1111

Table 27: Modbus memory map: programming variables (Table 12)

No. of stages			
Configuration variable	Address	Valid data window	Default value
No. of stages	113B	0-6 (Computer SMART III 6)	6
		0-12 (Computer SMART III 12)	12
		0-14 (Computer SMART III 14)	14

Table 28: Modbus memory map: programming variables (Table 13)

Connection and reclosing time			
Configuration variable	Address	Valid data window	Default value
Connection time	113C	0-999 seconds	10
Reclosing time	113D	0-999 seconds	50

Table 29: Modbus memory map: programming variables (Table 14)

Alarm: Voltage THD			
Configuration variable	Address	Valid data window	Default value
Low Value	1140	0 - 100 %	5
Hi Value	1141	0 - 100 %	8

Table 30: Modbus memory map: programming variables (Table 15)

Alarm: Current x I THD			
Configuration variable	Address	Valid data window	Default value
Low Value	1142	0 ... 9999 A	4
Hi Value	1143	0 ... 9999 A	5

Table 31: Modbus memory map: programming variables (Table 16)

Alarm: Temperature			
Configuration variable	Address	Valid data window	Default value
Low Value	1144	0 - 80 °C	65
Hi Value	1145	0 - 80 °C	70

Table 32: Modbus memory map: programming variables (Table 17)

Alarm: Leakage Current			
Configuration variable	Address	Valid data window	Default value
Search for the responsible stage	1146	0 (OFF), 1 (ON)	0
Value	1147	10 - 1000 mA	300
Stages enabled	1148	0 (No), 1 (Yes)	0

Table 33: Modbus memory map: programming variables (Table 18)

Alarm: Cos φ low			
Configuration variable	Address	Valid data window	Default value
Values of Cos φ low	1149	50 - 100 (Value x 100)	95
Current value	114A	0 - 9999 A	20
Type of Cos φ	114B	1 (Inductive)	1

Table 34: Modbus memory map: programming variables (Table 19)

Alarm: Cos φ high			
Configuration variable	Address	Valid data window	Default value
Values of Cos φ high	118A	50 - 100 (Value x 100)	98
Current value	118B	0 - 9999 A	20
Type of Cos φ	118C	0 (Capacitive)	0

Table 35: Modbus memory map: programming variables (Table 20)

Alarm: Fan			
Configuration variable	Address	Valid data window	Default value
Value	114C	0 - 80 °C	35
Enabled	114D	0 (OFF), 1 (ON)	0

Table 36: Modbus memory map: programming variables (Table 21)

Alarm: Voltage			
Configuration variable	Address	Valid data window	Default value
Overvoltage value	114E-114F	0-99999	440
No Voltage Value	1150-1151	0-99999	360

Table 37: Modbus memory map: programming variables (Table 22)

No. of operations			
Configuration variable	Address	Valid data window	Default value
No. of operations	1152-1153	1-99999	5000

Table 38: Modbus memory map: programming variables (Table 23)

Undervoltage trip			
Configuration variable	Address	Valid data window	Default value
Cut-off voltage threshold	1190	0-100 %	80

Table 39: Modbus memory map: programming variables (Table 24)

Enabling alarms			
Configuration variable	Address	Valid data window	Default value
Enable Alarm E01	1155	0 (OFF), 1 (ON)	1
Enable Alarm E02	1156		1
Enable Alarm E03	1157		1
Enable Alarm E04	1158		1
Enable Alarm E05	1159		0
Enable Alarm E06	115A		0
Enable Alarm E07	115B		0
Enable Alarm E08	115C		1
Enable Alarm E09	115D		0
Enable Alarm E10	115E		1
Enable Alarm E11	115F		1
Enable Alarm E12	1160		1

Table 39 (Continuation): Modbus memory map: programming variables (Table 24)

Enabling alarms			
Configuration variable	Address	Valid data window	Default value
Enable Alarm E13	1161	0 (No), 1 (Alarm relay), 2 (Digital output 1) 2 (Digital output 2)	0
Enable Alarm E14	1162		0
Enable Alarm E15	1163		0
Enable Alarm E16	1164		0
Enable Alarm E17	1165		0
Output associated with Alarm E01	1170		0
Output associated with Alarm E02	1171		0
Output associated with Alarm E03	1172		0
Output associated with Alarm E04	1173		0
Output associated with Alarm E05	1174		0
Output associated with Alarm E06	1175		0
Output associated with Alarm E07	1176		0
Output associated with Alarm E08	1177		0
Output associated with Alarm E09	1179		0
Output associated with Alarm E10	1179		0
Output associated with Alarm E11	117A		0
Output associated with Alarm E12	117B		0
Output associated with Alarm E13	117C	0	
Output associated with Alarm E14	117D	0	
Output associated with Alarm E15	117E	0	
Output associated with Alarm E16	117F	0	
Output associated with Alarm E17	1180	0	

C.- Deleting parameters

Parameters can be deleted using **Function 05**: writing a relay.

Table 40: Modbus memory map: deleting parameters

Deleting parameters		
Action	Address	Value to be sent
Deleting maximum values	200	FF
Deleting minimum values	210	FF
Deleting maximum and minimum values	220	FF
Deleting energies	230	FF
Deleting the stage search and stage enabling values of the leakage current alarm	240	FF
Deleting the no. of operations of all the relays	250	FF
Resetting alarms E14 and E15	260	FF
Restoring the default configuration values	300	FF

4.9.4. EXAMPLE OF A MODBUS QUERY

Query: Instantaneous value of the L1 phase voltage

Address	Function	Initial log	No. of logs	CRC
0A	04	0000	0002	70B0

Address: 0A, Peripheral number: 10 in decimal.

Function: 04, Read function.

Initial Log: 0000, log from which to start reading.

No. of logs: 0002, number of logs to be read.

CRC: 70B0, CRC character.

Response:

Address	Function	No. of Bytes	Log no. 1	Log no. 2	CRC
0A	04	04	0000	084D	8621

Address: 0A, Responding peripheral number: 10 in decimal.

Function: 04, Read function.

No. of bytes: 04, No. of bytes received.

Log: 0000084D, value of the L1 phase voltage: VL1 x 10: 212.5 V

CRC: 8621, CRC character.

5.- CONFIGURATION

The various configuration parameters of the device can be consulted and edited in the device setup menu.

The device always keeps the capacitors disconnected (except in the Plug&Play function).

This status is identified by the **SETUP** symbol in the device status area of the display (Figure 15).

To access the setup menu, long keystroke the  key (> 3 s).

The Password screen appears on the display. The password to be entered is a combination of keys:

   . It is unique and cannot be configured.



If it is not entered correctly, the device returns to the previous measurement screen.

If it is entered correctly and capacitors are connected, the disconnection screen appears.

Disconnection screen: used for the device to automatically disconnect all the stages before entering the configuration.

While in this screen, the device does not respond to the keypad.



The device automatically exits this screen, and this can take a certain amount of time.

5.1.- PLUG&PLAY

The Plug&Play function assists the user during the configuration of the device, since it automatically configures the basic parameters that are required for the device to perform its regulation functions correctly.

To start the Plug&Play process, press the  key.

The process enters edit mode. This is identified by the **EDIT** symbol and the flashing of the digits of the display.



Press the  key to switch from *OFF* to *START*

Press the  key to start the Plug&Play function. Once started, the device undertakes a process of connecting and disconnecting capacitors, measurement and calculation in order to obtain the following parameters of the capacitor bank:

- ✓ Connection type,
- ✓ Phase,
- ✓ Number of steps.
- ✓ Program
- ✓ C/K factor,

These parameters can also be configured manually from their respective screens.

When the Plug&Play process of the device is active, this screen is displayed with the **RUN** symbol flashing (it may take several minutes).

The capacitors are connected and disconnected during the process and this will be displayed on the screen.



Once the Plug&Play function of the device ends, if no errors occurred during the process, the results are shown by the display on two screens, as follows:



Connection type:

3U.3C: 3 voltages and 3 currents.

3U.1C: 3 voltages and 1 current.

2U.1U: 2 voltages and 1 current.

Phase

Cos φ III

L: Inductive / C: capacitive

+: consumed / -: generated

Press the  key to switch to the next screen of results.

Press the  key to exit the results screen.



No. steps detected

Program

C/K factor

Cos φ III

L: Inductive / C: capacitive

+: consumed / -: generated

Press the  key to switch to the previous screen of results.

Press the  key to exit the results screen.

If any errors occur during the execution of the Plug&Play function, the process will be aborted and the errors will be displayed on the screen. When a parameter has been calculated correctly before the error is detected, it will be displayed on the previously assigned line. The errors that can occur in the Plug&Play function are shown in **Table 41**.

Table 41: Code of Plug&Play errors.



Code	Description
P00	There are three possible causes that can prevent the Plug&Play process from starting: - Some stages are cancelled by the leakage current alarm. - Some stages are forced in the configuration "5.14. - STATUS OF THE STAGES". - The reclosing time is longer than 280 seconds.
P01	Error when searching for the Connection Type. See connection diagrams.

Table 41 (Continuation): Code of Plug&Play errors.

Code	Description
<i>P02</i>	Phase not found. Cosine out of range (between 0.62 and 0.99 inductive).
<i>P03</i>	Unstable measurement. Load changes during the process.
<i>P04</i>	Error in the measurement of the largest capacitor.
<i>P05</i>	No capacitors found.
<i>P06</i>	Incorrect measurement of the number of capacitors.
<i>P07</i>	Incorrect measurement of the ratio of the first capacitor.
<i>P08</i>	Possible error in the program calculated.
<i>P09</i>	C/K out of range.

In the event of a *P00* error, in other words, if some capacitors are cancelled by the leakage current alarm, forced in the configuration or have a reclosing time of more than 280 seconds, the Plug&Play function is not executed until the problem is solved.

The Plug&Play function is designed to assist with the installation of the reactive energy compensation system, with the initial configuration of the regulator or when there are changes in the system (new regulator, new cabling, new stage, etc.). For this reason, it is necessary prior to the Plug&Play function to solve the possible problems with faulty capacitors by means of maintenance or replacement, as well as to configure all the stages in Auto mode, as they come by default.

	<p>Conditions for the correct operation of the Plug&Play function:</p> <ul style="list-style-type: none"> ✓ The system should be maintained with an inductive cosine of 0.62 to 0.99 throughout the process. ✓ The power in the system should be stable. Any major load changes (>10 % in less than 20 seconds) would result in an incorrect calculation of the capacitor power ratings. ✓ There must be enough current in the system, above 100 mA AC at the input of the regulator. ✓ If the load is unbalanced, the correct operation of the Plug&Play function will depend on the phase to which the current transformer is connected.
	<p>Once the Plug&Play function is finished, the primary of the current transformer needs to be configured in order for the device to measure the current and the powers correctly.</p>

Press the  key to move on to the next configuration point.

If no keys are pressed for 5 minutes, the device switches to the simulation screen, "**5.30.- SIMULATION SCREEN**".

5.2.- CURRENT TRANSFORMATION RATIO

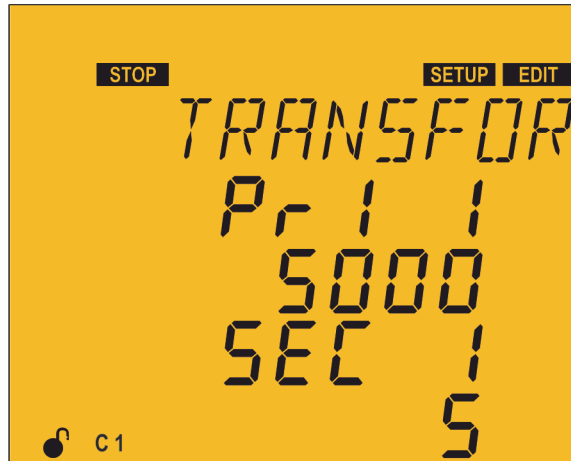

The primary and secondary value of the current transformer is configured in this point.

Press the  key to enter edit mode. It is identified by the **EDIT** symbol and the flashing of the digits to be modified.



The  key increases the digit value or shows the next option.

The  key reduces the digit value or shows the previous option.

The  key skips to the previous digit and the  key skips to the next digit.

Press  to validate the data; the **EDIT** symbol disappears from the display.

Current primary:

Maximum value: 9999.

Minimum value: 1.

Current secondary:

Possible values: 1 or 5.

Maximum possible current ratio: 2500.

Note: The current ratio is the ratio between the current primary and secondary.

Maximum value of the current ratio x the voltage ratio: 200000.

If the value entered is lower than the minimum value or higher than the maximum value, the backlight of the display flashes and the value entered is replaced with the minimum or maximum value, or with the last value validated.

Press the  key to access the next programming step.

If no keys are pressed for 5 minutes, the device switches to the simulation screen, "5.30.- SIMULATION SCREEN".

5.3.- TARGET COS φ

The $\cos \varphi$ makes it possible to define the power factor required for the installation. The **Computer SMART III** device inserts the number of capacitors required in order to get as close to this target value as possible. Since the regulation is by stages, it does not perform any operations until the uncompensated demand is at least 70 % of the power of the smallest stage or the compensation surplus is 70 % of the power of the smallest stage.

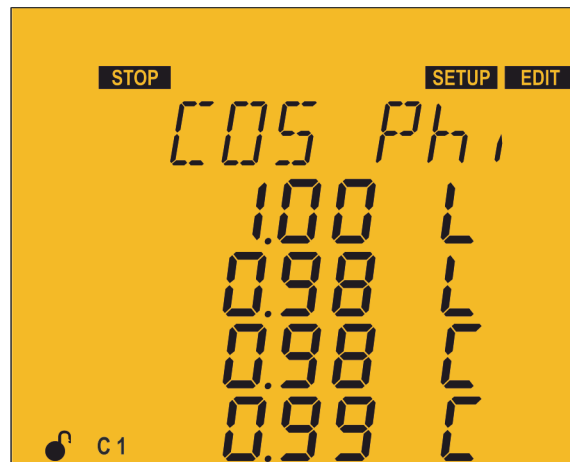



Four target cosines can be configured. According to the status of the digital inputs (see "4.7.- INPUTS") the device admits one of the 4 programmed cosines.

For every cosine, the value is programmed as is the option of being inductive L or capacitive \bar{L} .

Press the  key to enter edit mode. It is identified by the **EDIT** symbol and the flashing of the digits to be modified.

The  key increases the digit value or shows the next option.

The  key reduces the digit value or shows the previous option.

The  key skips to the previous digit and the  key skips to the next digit.

Press  to validate the data; the **EDIT** symbol disappears from the display.

Maximum value: 1.00.

Minimum value: 0.50.

If the value entered is lower than the minimum value or higher than the maximum value, the backlight of the display flashes and the value entered is replaced with the minimum or maximum value, or with the last value validated.

Press the  key to access the next programming step.

If no keys are pressed for 5 minutes, the device switches to the simulation screen, "5.30.- SIMULATION SCREEN".

5.4.- CONNECTION AND RECLOSING TIME

In this point the action times of the device are configured in seconds:

t_{on} is the minimum time between the connection and disconnection of a single stage.

t_{rEc} is the maximum time between the disconnection and connection of a single stage.



t_{rEc} must be greater than T_{ON} ; ideally, it should be 5 times greater.



Press the  key to enter edit mode. It is identified by the **EDIT** symbol and the flashing of the digits to be modified.

The  key increases the digit value.

The  key reduces the digit value.

The  key skips to the previous digit and the  key skips to the next digit.

Press  to validate the data; the **EDIT** symbol disappears from the display.

t_{on} :

Maximum value: 999.

Minimum value: 4.

t_{rEc} :

Maximum value: 999.

Minimum value: 20.

If the value entered is lower than the minimum value or higher than the maximum value, the backlight of the display flashes and the value entered is replaced with the minimum or maximum value, or with the last value validated.

Press the  key to access the next programming step.

If no keys are pressed for 5 minutes, the device switches to the simulation screen, "5.30.- SIMULATION SCREEN".

5.5.- CONNECTION TYPE

In this point the connection type of the installation is selected, where:

3U3C: 3 voltages + neutral and 3 currents.

3U 1C: 3 voltages + neutral and 1 current.

2U 1C: 2 voltages and 1 current.



Press the  key to enter edit mode. It is identified by the **EDIT** symbol and the flashing of the digits to be modified.

The  key shows the next option and the  key shows the previous option.

Press  to validate the data; the **EDIT** symbol disappears from the display.

Press the  key to access the next programming step.

If no keys are pressed for 5 minutes, the device switches to the simulation screen, "**5.30.- SIMULATION SCREEN**".

5.6.- PHASE CONNECTION

This parameter is used to adapt the device to the various options for connecting the power supply and measurement cables and the current transformers to the phases of the three-phase system.

The connection screen changes according to the connection type programmed in the preceding point.

✓ Connection type **3U 1C** or **2U 1C**

If a connection with a single current has been selected (**3U 1C** or **2U 1C**), one of the 6 possible phases indicated in **Table 42** are selected in this screen.

The selection of one or another of the options must be made when inductive reactive power with an inductive $\cos \varphi$ of 0.6 to 1 is being consumed in the installation at the time of adjustment. The various options are tried until the screen shows a $\cos \varphi$ of 0.6 to 1 (the display of the $\cos \varphi$ is only informative, not editable).



Press the  key to enter edit mode. It is identified by the **EDIT** symbol and the flashing of the digits to be modified.

The  key shows the next option and the  key shows the previous option.

Press  to validate the data; the **EDIT** symbol disappears from the display.

Press the  key to access the next programming step.

If no keys are pressed for 5 minutes, the device switches to the simulation screen, "5.30.- SIMULATION SCREEN".

Table 42:Phase connection options.

Phases	V measurement phase	CT connection phase
<i>PH1</i>	L1-L2-L3	L1
<i>PH2</i>	L1-L2-L3	L2
<i>PH3</i>	L1-L2-L3	L3
<i>PH4</i>	L1-L2-L3	L1 (inverted transformer)
<i>PH5</i>	L1-L2-L3	L2 (inverted transformer)
<i>PH6</i>	L1-L2-L3	L3 (inverted transformer)

✓ Connection type 3U3C

If the connection with three currents has been selected (3U3C), each current is associated with its voltage and the direction of the current is indicated in this screen.

d: direct.

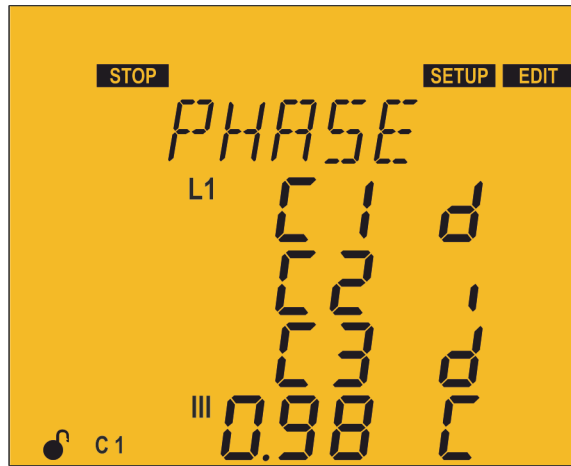

l: reverse.



Press the  key to enter edit mode. It is identified by the **EDIT** symbol and the flashing of the digits to be modified.

The  key shows the next option.

The  key shows the previous option.

The  key skips to the previous voltage and the  key skips to the next voltage.

Press  to validate the data; the **EDIT** symbol disappears from the display.

Press the  key to access the next programming step.

If no keys are pressed for 5 minutes, the device switches to the simulation screen, "5.30.- SIMULATION SCREEN".

5.7.- NO. OF STAGES

In this point the number of stages is selected, in other words the number of relay outputs that the device will have. According to the model, **Computer SMART III 6**, **SMART III 12** or **SMART III 14**, it can be configured with up to 6 or up to 12 outputs.



Press the  key to enter edit mode. It is identified by the **EDIT** symbol and the flashing of the digits to be modified.

The  key shows the next option.

The  key shows the previous option.

Press  to validate the data; the **EDIT** symbol disappears from the display.

Press the  key to access the next programming step.

If no keys are pressed for 5 minutes, the device switches to the simulation screen, "5.30.- SIMULATION SCREEN".

5.8.- PROGRAM

The device is made up of stages with different powers. The base power (value 1) will be that of the stage with the lowest power. The powers of all the other stages will depend on the power of the first stage.

Example:

Program 1.1.1.1, all the stages have the same power as the first one.

Program 1.2.4.4, the second stage has twice the power and the next ones have four times the power of the first one. (See "4.1.4. REGULATION PROGRAM")

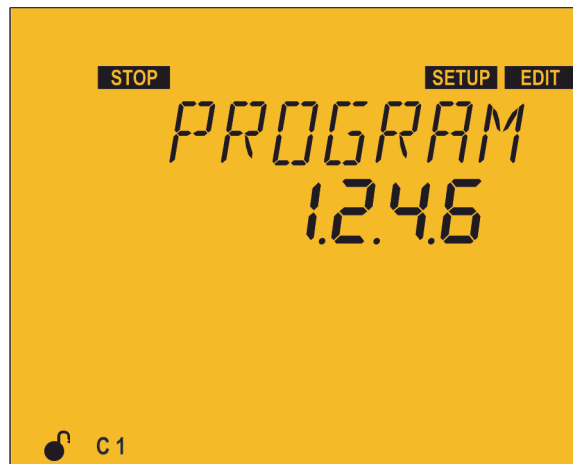



When configuring the program, remember that the subsequent stage cannot be lower than the prior stage, and that the first stage is always 1.

Press the  key to enter edit mode. It is identified by the **EDIT** symbol and the flashing of the digits to be modified.

The  key increases the digit value.

The  key reduces the digit value.

The  key skips to the previous digit and the  key skips to the next digit.

Press  to validate the data; the **EDIT** symbol disappears from the display.

Minimum value: 1.1.1.1

Maximum value: 1.9.9.9

Press the  key to access the next programming step.

If no keys are pressed for 5 minutes, the device switches to the simulation screen, "5.30.- SIMULATION SCREEN".

5.9.- C/K FACTOR

The C/K factor is adjusted according to the reactive current provided by the smallest stage, measured in the secondary of the current transformer (CT). The adjustment value of this factor therefore depends on the power of the smallest stage, the ratio of the CTs and the network voltage.

Table 43 and **Table 44** provide the values to which the C/K should be adjusted for a 400 V AC network between phases, various transformer ratios and powers of the smallest stage.

Table 43: C/K factor (table 1).

CT Ratio (Ip / Is)	Power of the smallest stage at 400 V (in kvar)													
	2.5	5.0	7.5	10.0	12.5	15.0	20.0	25.0	30.0	40.0	50.0	60.0	75.0	80.0
150/5	0.12	0.24	0.36	0.48	0.60	0.72	0.96							
200/5	0.09	0.18	0.27	0.36	0.45	0.54	0.72	0.90						
250/5	0.07	0.14	0.22	0.29	0.36	0.43	0.58	0.72	0.87					
300/5	0.06	0.12	0.18	0.24	0.30	0.36	0.48	0.60	0.72	0.96				
400/5	0.05	0.09	0.14	0.18	0.23	0.24	0.36	0.48	0.58	0.72	0.87			
500/5		0.07	0.11	0.14	0.18	0.22	0.29	0.36	0.45	0.54	0.72	0.87		
600/5		0.06	0.09	0.12	0.15	0.18	0.24	0.30	0.36	0.48	0.60	0.72	0.90	0.96
800/5			0.07	0.09	0.11	0.14	0.18	0.23	0.27	0.36	0.45	0.54	0.68	0.72
1000/5			0.05	0.07	0.09	0.11	0.14	0.18	0.22	0.29	0.36	0.43	0.54	0.57
1500/5				0.05	0.06	0.07	0.10	0.12	0.14	0.19	0.24	0.29	0.36	0.38
2000/5						0.05	0.07	0.09	0.11	0.14	0.18	0.22	0.27	0.28
2500/5							0.06	0.07	0.09	0.12	0.14	0.17	0.22	0.23
3000/5							0.05	0.06	0.07	0.10	0.12	0.14	0.18	0.19
4000/5									0.05	0.07	0.09	0.11	0.14	0.14

If the capacitor power reference of 440 V is used for a 400 V network voltage, the table is **Table 44**.

Table 44: C/K factor (table 2).

CT Ratio (Ip / Is)	Power of the smallest stage at 440 V (in kvar)													
	2.5	5.0	7.5	10.0	12.5	15.0	20.0	25.0	30.0	40.0	50.0	60.0	75.0	80.0
150/5	0.09	0.18	0.27	0.36	0.45	0.54	0.72	0.90						
200/5	0.07	0.14	0.20	0.27	0.34	0.41	0.54	0.68	0.81					
250/5	0.05	0.11	0.16	0.22	0.27	0.33	0.43	0.54	0.65	0.87				
300/5	0.05	0.09	0.14	0.18	0.23	0.27	0.36	0.45	0.54	0.72	0.90			
400/5		0.07	0.10	0.14	0.17	0.20	0.27	0.34	0.41	0.54	0.68	0.81		
500/5		0.05	0.08	0.11	0.14	0.16	0.22	0.27	0.33	0.43	0.54	0.65	0.81	0.87
600/5		0.05	0.07	0.09	0.11	0.14	0.18	0.23	0.27	0.36	0.45	0.54	0.68	0.72
800/5			0.05	0.07	0.08	0.10	0.14	0.17	0.20	0.27	0.34	0.41	0.51	0.54
1000/5			0.04	0.05	0.07	0.08	0.11	0.14	0.16	0.22	0.27	0.33	0.41	0.43
1500/5				0.04	0.05	0.05	0.07	0.09	0.11	0.14	0.18	0.22	0.27	0.29
2000/5						0.04	0.05	0.07	0.08	0.11	0.14	0.16	0.20	0.22
2500/5							0.04	0.05	0.07	0.09	0.11	0.13	0.16	0.17
3000/5							0.04	0.05	0.05	0.07	0.09	0.11	0.14	0.14
4000/5									0.04	0.05	0.07	0.08	0.10	0.11

For other voltages or conditions not included in the table, the value of C/K can be obtained by means of a simple calculation.

✓ Calculating the C/K Factor

The equation for calculating the C/K factor is:

$$C/K = \frac{I_c}{K}$$

where, **I_c**: is the smallest capacitor current.

K: the current transformer transformation ratio.

To calculate **I_c** it is necessary to know the reactive power of the smallest capacitor **Q** and the network voltage **V**.

$$I_c = \frac{Q}{\sqrt{3} \cdot V}$$

The transformation ratio K is calculated as:

$$K = I_{prim} / I_{sec}$$

where, **I_{prim}** : is the nominal current of the transformer primary.

I_{sec}: is the current of the transformer secondary.

Example: In a 400 V device the smallest capacitor is of 60 kvar with a current transformer having a ratio of 500/5, and the calculation would be made as follows:

$$\text{Current of the smallest capacitor, } I_c = \frac{60000}{\sqrt{3} \cdot 400}$$

$$\text{K Factor } K = 500/5 = 100$$

The C/K value is: **0.866**.

If the power of 60 kvar is referenced at 440 V, it should be multiplied by $V_{red}^2 / 440^2$ in which case the C/K value of the previous example would be **0.72**.



If the C/K is configured lower than the actual value, connections and disconnections would occur continuously with few load variations (the system performs more operations than necessary).





If the C/K is configured higher, the regulator requires a higher demand for reactive power in order to switch and perform fewer operations.

Press the  key to enter edit mode. It is identified by the **EDIT** symbol and the flashing of the digits to be modified.



The  key skips to the previous digit.

The  key skips to the next digit.

The  key increases the digit value and the  key reduces the digit value.

Press  to validate the data; the **EDIT** symbol disappears from the display.

Minimum value: 0.02

Maximum value: 1.0

If the value entered is lower than the minimum value or higher than the maximum value, the backlight of the display flashes and the value entered is replaced with the minimum or maximum value, or with the last value validated.

Press the  key to access the next programming step.

If no keys are pressed for 5 minutes, the device switches to the simulation screen, "5.30.- SIMULATION SCREEN".

5.10.- VOLTAGE LEVEL

In this point the voltage level of the device is selected. There are two possible options:

Low.V: Low voltage

High.V: High voltage



When the high-voltage option is selected, the device will have some of its functions disabled. The disabled functions are:

- ✓ The Plug&Play process cannot be carried out.
- ✓ The AutoTest process cannot be carried out.
- ✓ The leakage current is not measured and the related alarms cannot be enabled.

Press the  key to enter edit mode. It is identified by the **EDIT** symbol and the flashing of the digits to be modified.

The  key shows the next option.

The  key shows the previous option.

Press  to validate the data; the **EDIT** symbol disappears from the display.

Press the  key to access the next programming step.

If no keys are pressed for 5 minutes, the device switches to the simulation screen, "5.30.- SIMULATION SCREEN".

5.11.- EXPERT SETUP

In this point it is possible to decide whether to access the expert setup menu.

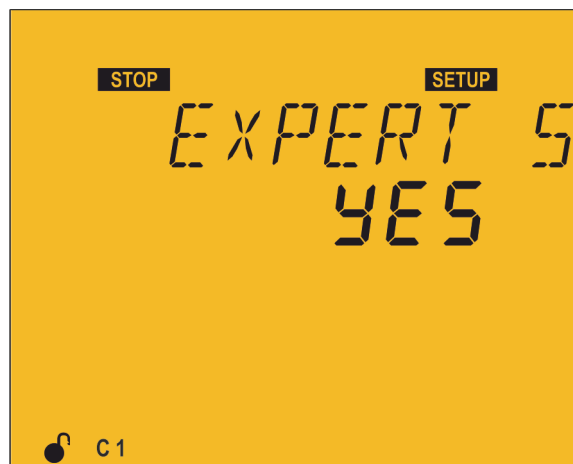

If the **YES** option is selected, the next programming step will be the voltage transformation ratio ("5.12.- VOLTAGE TRANSFORMATION RATIO")

When the **NO** option is selected, the display returns to the Plug&Play configuration screen ("5.1.- PLUG&PLAY")

Press the  key to enter edit mode. It is identified by the **EDIT** symbol and the flashing of the digits to be modified.

The  key shows the next option.

The  key shows the previous option.

Press  to validate the data; the **EDIT** symbol disappears from the display.

Press the  key to access the next programming step

If no keys are pressed for 5 minutes, the device switches to the simulation screen, "5.30.- SIMULATION SCREEN".

5.12.- VOLTAGE TRANSFORMATION RATIO

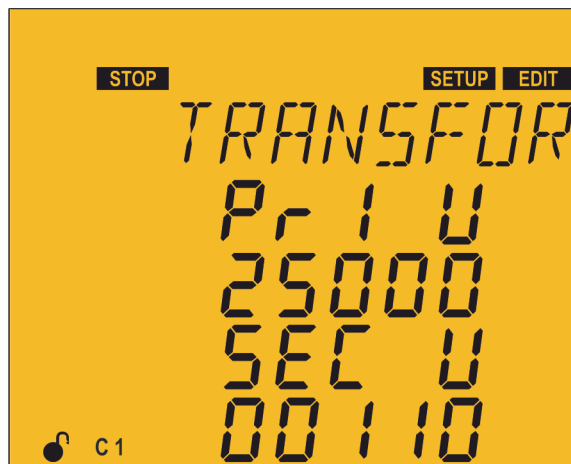

In this point the primary and secondary value of the voltage transformer can be configured.

Press the  key to enter edit mode. It is identified by the **EDIT** symbol and the flashing of the digits to be modified.



The  key increases the digit value.

The  key reduces the digit value.

The  key skips to the previous digit and the  key skips to the next digit.

Press  to validate the data; the **EDIT** symbol disappears from the display.

Voltage primary:

Maximum value: 99999.

Minimum value: 1.

Voltage secondary:

Maximum value: 99999.

Minimum value: 1.

Maximum possible voltage ratio: 1000.

Note: The voltage ratio is the ratio between the voltage primary and secondary.

Maximum value of the current ratio x the voltage ratio: 200000.

If the value entered is lower than the minimum value or higher than the maximum value, the backlight of the display flashes and the value entered is replaced with the minimum or maximum value, or with the last value validated.

Press the  key to access the next programming step.

If no keys are pressed for 5 minutes, the device switches to the simulation screen, "5.30.- SIMULATION SCREEN".

5.13.- HYSTERESIS

The L (inductive) and C (capacitive) hysteresis values of the target $\cos \varphi$ are specified in this section. As long as the $\cos \varphi$ is within this range, the device does not connect any paths, but it can disconnect them.





The configuration of the hysteresis affects the four target $\cos \varphi$ specified.

Note: If the hysteresis is activated on the display screens, the symbol **RUN** flashes every 5 seconds.

Press the  key to enter edit mode. It is identified by the **EDIT** symbol and the flashing of the digits to be modified.

The  key increases the digit value or shows the next option.

The  key reduces the digit value or shows the next option.

The  key skips to the previous digit and the  key skips to the next digit.

Press  to validate the data; the **EDIT** symbol disappears from the display.

Maximum value: 0.10.

Minimum value: 0.00.

If the value entered is lower than the minimum value or higher than the maximum value, the backlight of the display flashes and the value entered is replaced with the minimum or maximum value, or with the last value validated.

Press the  key to access the next programming step.

If no keys are pressed for 5 minutes, the device switches to the simulation screen, "5.30.- SIMULATION SCREEN".

5.14.- STATUS OF THE STAGES

This parameter is repeated for each of the 6, 12 or 14 possible stages, offering the opportunity to force their status without paying attention to the operation performed by the actual device.

In order to identify which of the 14 stages is being configured, the screen shows C 1, C 2, etc.



The configuration options for each stage are as follows:

- ✓ **AUTO**: The status of the stage depends on the operation performed by the device.
- ✓ **ON**: Stage forced to ON, always connected.
- ✓ **OFF**: Stage forced to OFF, always disconnected.
- ✓ **ON nC**: Stage forced to ON, always connected but the system does not take into account its connected power.

By default, all the stages are configured as **AUTO**.

On the measurement screens, the forced states of the stages are shown by activating the bottom line of the capacitor status bar. ("4.4.1. STATUS OF THE CAPACITORS")

Press the  key to enter edit mode. It is identified by the **EDIT** symbol and the flashing of the digits to be modified.

The  key shows the next option.

The  key shows the previous option.

The  key skips to the previous stage.

The  key skips to the next stage.

Press  to validate the data; the **EDIT** symbol disappears from the display.

Press the  key to access the next programming step.

If no keys are pressed for 5 minutes, the device switches to the simulation screen, "5.30.- SIMULATION SCREEN".

5.15.- DISPLAY

In this point the lighting status of the screen and its language can be configured.

Press the  key to enter edit mode. It is identified by the **EDIT** symbol and the flashing of the digits to be modified.



The following display configuration options are available:

- ✓ **On**: the display light is always on.
- ✓ **OFF**: the light is always off.
- ✓ **AUTO**: the light comes on when a key is pressed and switches off when no keys have been pressed for 5 minutes.

The light level is also configured between 0 % and 100 % when the display is on.

The display language options are as follows:

- ✓ **ESP**: Spanish, **ENG**: English, **FRA**: French, **TR**: Turkish.

The  key increases the digit value or shows the next option.

The  key reduces the digit value or shows the next option.

The  key skips to the next parameter.

The  key skips to the next parameter.

Press  to validate the data; the **EDIT** symbol disappears from the display.

Press the  key to access the next programming step.

If no keys are pressed for 5 minutes, the device switches to the simulation screen, "5.30.- SIMULATION SCREEN".

5.16.- ANALOGUE BAR

In this point the parameter to be displayed in the analogue bar ("**4.4.3. ANALOGUE BAR**") can be configured.

Press the  key to enter edit mode. It is identified by the **EDIT** symbol and the flashing of the digits to be modified.



The following display options are available for the analogue bar:

- ✓ *POtC* : the percentage of power connected to the capacitor bank relative to the total power.
- ✓ *tHdl* : the Current THD of each phase.
- ✓ *I* : the current % of each one of the phases.
- ✓ *n0* : no parameters are displayed.

The  key shows the next option.

The  key shows the previous option.

Press  to validate the data; the **EDIT** symbol disappears from the display.

Press the  key to access the next programming step.

If no keys are pressed for 5 minutes, the device switches to the simulation screen, "**5.30.- SIMULATION SCREEN**".

5.17.- FAN

In this point the activation of the relay output associated with the fan can be configured.

It is possible to configure whether or it is enabled *On* or not *OFF*, as well as the temperature above which it is to be activated or deactivated.

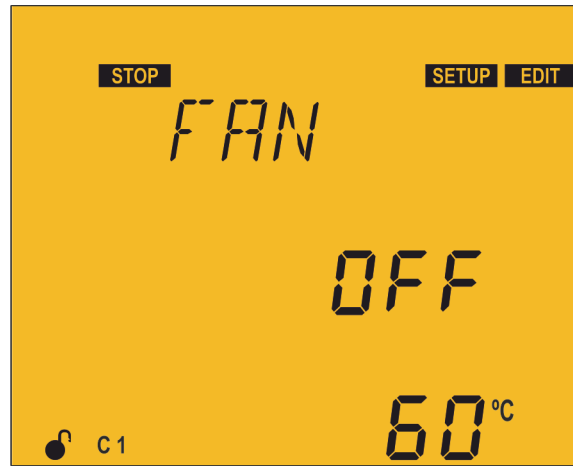

The device has a hysteresis value of 5°C when disconnecting the fan, in order to avoid continuous connections and disconnections.



Press the  key to enter edit mode. It is identified by the **EDIT** symbol and the flashing of the digits to be modified.

The  key increases the digit value or shows the next option.

The  key reduces the digit value or shows the next option.

The  key skips to the previous parameter and the  key skips to the next parameter.

Press  to validate the data; the **EDIT** symbol disappears from the display.

Maximum value: 80°C.

Minimum value: 0°C.

If the value entered is lower than the minimum value or higher than the maximum value, the backlight of the display flashes and the value entered is replaced with the minimum or maximum value, or with the last value validated.

Press the  key to access the next programming step.

If no keys are pressed for 5 minutes, the device switches to the simulation screen, **"5.30.- SIMULATION SCREEN"**.

5.18.- UNDERVOLTAGE TRIP

At this point we configure the voltage threshold over which the undervoltage trip function acts. This function disables all the steps enabled in the event of any measured phase-phase voltages presenting a value below the configured threshold. It will not enable them again until the measured phase-phase voltages do not exceed the threshold.

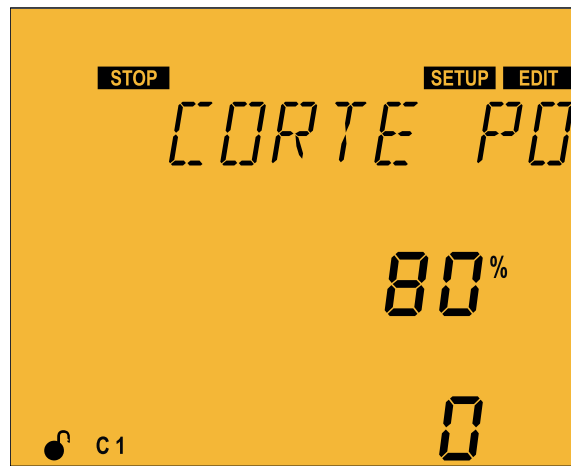



Press the  key to enter edit mode. It is identified by the **EDIT** symbol and the flashing of the digits to be modified.

The voltage threshold is programmed as a percentage of the configured primary voltage's value ("**5.12.- VOLTAGE TRANSFORMATION RATIO**").

The  key increases the digit value or shows the next option.

The  key reduces the digit value or shows the next option.

The  key skips to the previous parameter and the  key skips to the next parameter.

Press  to validate the data; the **EDIT** symbol disappears from the display.

Maximum value: 0 %.

Minimum value: 100 %.

Note: If 0% is programmed, the functionality is disabled.

Note: The value displayed in the fourth row (0 in the image) is not editable and indicates the number of times that the Undervoltage trip function has been activated. This value is reset each time the value is reconfigured.

Press the  key to access the next programming step.

If no keys are pressed for 5 minutes, the device switches to the simulation screen, "**5.30.- SIMULATION SCREEN**".

5.19.- COMMUNICATIONS

In this point the RS-485 communication parameters can be configured.



Press the  key to enter edit mode. It is identified by the **EDIT** symbol and the flashing of the digits to be modified.

The parameters to be configured are:

The **peripheral number** assigned, from 1 to 254.

The **transmission speed**, BaudRate: 9600 or 19200.

The **parity**:

- ✓ none: no parity.
- ✓ Even: even parity.
- ✓ Odd: odd parity.

The **number of stop bits**: 1 or 2

The  key increases the digit value or shows the next option.

The  key reduces the digit value or shows the next option.

The  key skips to the previous digit or the previous parameter.

The  key skips to the next digit or the next parameter.

Press  to validate the data; the **EDIT** symbol disappears from the display.

If the value entered is lower than the minimum value or higher than the maximum value, the backlight of the display flashes and the value entered is replaced with the minimum or maximum value, or with the last value validated.

Press the  key to access the next programming step.

If no keys are pressed for 5 minutes, the device switches to the simulation screen, "5.30.- SIMULATION SCREEN".

5.20.- CLEAR

In this point it is possible to configure whether or not to delete (*YES* or *no*) the maximum and minimum values, the energies and the number of connections of the stages.





Press the  key to enter edit mode. It is identified by the **EDIT** symbol and the flashing of the digits to be modified.

The following parameters can be deleted:

- ✓ *n*: maximum and minimum values.
- ✓ *E*: energies.
- ✓ *C*: number of connections of the stages.

The  key shows the next option.

The  key shows the previous option.

The  key skips to the previous parameter and the  key skips to the next parameter.

Press  to validate the data; the **EDIT** symbol disappears from the display.

Press the  key to access the next programming step.

If no keys are pressed for 5 minutes, the device switches to the simulation screen, "*5.30.- SIMULATION SCREEN*".

5.21.- ENABLING ALARMS

This screen is repeated for every type of Error or Alarm (from *E01* to *E17*); see **Table 10**. In it the enabling or disabling of each error or alarm can be configured, as can whether or not to associate it with the activation of a relay or a digital output.



The  key skips to the previous error.

The  key skips to the next error.

Press the  key to enter edit mode. It is identified by the **EDIT** symbol and the flashing of the digits to be modified.

The parameters to be configured are:



Enabling *On* or disabling ***OFF*** the error or alarm.

Association with a relay or digital output alarm:

- ✓ *rELE*: the activation of the alarm is associated with the alarm relay.
- ✓ *d1*: the activation of the alarm is associated with digital output 1.
- ✓ *d2*: the activation of the alarm is associated with digital output 2.
- ✓ *n0*: not associated with any relay or digital output.

The  key shows the next option.

The  key shows the previous option.

The  key skips to the previous parameter and the  key skips to the next parameter.

Press  to validate the data; the **EDIT** symbol disappears from the display.

Press the  key to access the next programming step.

If no keys are pressed for 5 minutes, the device switches to the simulation screen, "**5.30.- SIMULATION SCREEN**".

5.22.- VOLTAGE ALARMS

In this point the phase-phase voltage thresholds above which the overvoltage alarm (*E05*) and the no voltage alarm (*E06*) should be configured.

Note: The alarm must be enabled ("*5.21.- ENABLING ALARMS*").



Press the  key to enter edit mode. It is identified by the  symbol and the flashing of the digits to be modified.

In order to avoid possible false activations of said alarms, they have a predefined delay of 5 seconds.

The parameters to be configured are:



The **value of the overvoltage alarm:** *HI* .

The **value of the no voltage alarm:** *LO* .

When any of the two alarms are triggered, the device enters the **Disconnection** status and disconnects all the stages. The device does not return to its normal operating status until the cause for the alarm disappears.

The  key increases the digit value.

The  key reduces the digit value.

The  key skips to the previous digit and the  key skips to the next digit.

Press  to validate the data; the  symbol disappears from the display.

Overvoltage alarm:

Maximum value: 99999 V

Minimum value: 0 V

No voltage alarm:

Maximum value: 99999 V

Minimum value: 0 V

If the value entered is lower than the minimum value or higher than the maximum value, the backlight of the display flashes and the value entered is replaced with the minimum or maximum value, or with the last value validated.

Press the  key to access the next programming step.

If no keys are pressed for 5 minutes, the device switches to the simulation screen, "5.30.- SIMULATION SCREEN".

5.23.- COS φ LOW ALARM

In this point the lower limit for action of the cos φ alarm can be configured. It is activated every time the value of the cos φ drops below the configured value and the current is higher than programmed.

Note: The alarm must be enabled ("5.21.- ENABLING ALARMS").



Press the  key to enter edit mode. It is identified by the **EDIT** symbol and the flashing of the digits to be modified.

In order to avoid possible false activations of said alarms, they have a predefined delay of 15 seconds.

The parameters to be configured are:

The **current value**.

The **cos φ value**, it is inductive L .

The  key increases the digit value or shows the next option.

The  key reduces the digit value or shows the next option.

The  key skips to the previous digit and the  key skips to the next digit.

Press  to validate the data; the **EDIT** symbol disappears from the display.

Current:

Maximum value: 9999 A

Minimum value: 0 A

cos φ :

Maximum value: 1.00

Minimum value: 0.50

If the value entered is lower than the minimum value or higher than the maximum value, the backlight of the display flashes and the value entered is replaced with the minimum or maximum value, or with the last value validated.

Press the  key to access the next programming step.

If no keys are pressed for 5 minutes, the device switches to the simulation screen, "5.30.- SIMULATION SCREEN".

5.24.- COS φ HIGH ALARM

The high limit of the cos φ alarm is set at this point. This is activated whenever the value of cos φ is above the specified value and the current is higher than the programmed value.

Note: The alarm must be enabled ("5.21.- ENABLING ALARMS").



Press the  key to enter edit mode. It is identified by the **EDIT** symbol and the flashing of the digits to be modified.

In order to avoid possible false activations of said alarms, they have a predefined delay of 15 seconds.

The **current value**.

The **cos φ value**, it is capacitive \bar{C} .

The  key increases the digit value or shows the next option.

The  key reduces the digit value or shows the next option.

The  key skips to the previous digit and the  key skips to the next digit.

Press  to validate the data; the **EDIT** symbol disappears from the display.

Current:

Maximum value: 9999 A

Minimum value: 0 A

$\cos \varphi$:

Maximum value: 1.00

Minimum value: 0.50

If the value entered is lower than the minimum value or higher than the maximum value, the backlight of the display flashes and the value entered is replaced with the minimum or maximum value, or with the last value validated.

Press the  key to access the next programming step.

If no keys are pressed for 5 minutes, the device switches to the simulation screen, "5.30.- SIMULATION SCREEN".

5.25.- VOLTAGE THD ALARM

In this point the thresholds above which the Voltage THD alarm ($E08$) is activated can be configured. The programmed values are useful for the 3 phases which the device measures.

Note: The alarm must be enabled ("5.21.- ENABLING ALARMS").



Press the  key to enter edit mode. It is identified by the **EDIT** symbol and the flashing of the digits to be modified.

The parameters to be configured are:

✓ The **Lo value** : when the device exceeds this value for 30 minutes, alarm $E08$ is triggered, and if alarm $E11$ is enabled, the **Computer SMART III** device enters the **No Connection** status and activates alarm $E11$.

✓ The **Hi value**: if the device exceeds this value for 30 seconds, alarm $E08$ is triggered, and if alarm $E12$ is enabled, the **Computer SMART III** device enters the **Disconnection** status and activates alarm $E12$.



If the device falls back under the **Lo** value during 10 minutes, it deactivates the alarms and returns to the normal operating status.

In the **No Connection** status, the device does not connect the stages, but also does not disconnect them if the operation requires it.

In the **Disconnection** status, it disconnects the stages and does not allow them to connect.

The  key increases the digit value.

The  key reduces the digit value.

The  key skips to the previous digit and the  key skips to the next digit.

Press  to validate the data; the **EDIT** symbol disappears from the display.

Lo Value and **Hi Value**:

Maximum value: 99 %

Minimum value: 1 %

If the value entered is lower than the minimum value or higher than the maximum value, the backlight of the display flashes and the value entered is replaced with the minimum or maximum value, or with the last value validated.

Press the  key to access the next programming step.

If no keys are pressed for 5 minutes, the device switches to the simulation screen, "**5.30.- SIMULATION SCREEN**".

5.26.- CURRENT x I THD ALARM

In this point the thresholds above which the alarm for the % of the value of the current x ITHD (**E09**) is activated can be configured. The programmed values are useful for the 3 phases which the device measures.

Note: The alarm must be enabled ("**5.21.- ENABLING ALARMS**").



Press the  key to enter edit mode. It is identified by the **EDIT** symbol and the flashing of the digits to be modified.

The value to be programmed in this alarm corresponds directly to the value of the total harmonic current to be considered as the setpoint. **For example:** If you want to program a L_{α} setpoint value when exceeding a harmonic current of 200 A measured by the regulator, program 00200 directly in this section.

The parameters to be configured are:

- ✓ The L_{α} value: when the device exceeds this value for 30 minutes, alarm $E09$ is triggered, and if alarm $E11$ is enabled, the **Computer SMART III** device enters the **No Connection** status and activates alarm $E11$.
- ✓ The H_i value: if the device exceeds this value for 30 seconds, alarm $E09$ is triggered, and if alarm $E12$ is enabled, the **Computer SMART III** device enters the **Disconnection** status and activates alarm $E12$.

If the device falls back under the L_{α} value during 10 minutes, it deactivates the alarms and returns to the normal operating status.

In the **No Connection** status, the device does not connect the stages, but also does not disconnect them if the operation requires it.

In the **Disconnection** status, it disconnects all the stages and does not allow them to connect.

The  key increases the digit value.

The  key reduces the digit value.

The  key skips to the previous digit and the  key skips to the next digit.

Press  to validate the data; the **EDIT** symbol disappears from the display.

L_{α} Value and H_i Value:

Maximum value: 9999.

Minimum value: 1

If the value entered is lower than the minimum value or higher than the maximum value, the backlight of the display flashes and the value entered is replaced with the minimum or maximum value, or with the last value validated.

Press the  key to access the next programming step.

If no keys are pressed for 5 minutes, the device switches to the simulation screen, "**5.30.- SIMULATION SCREEN**".

5.27.- TEMPERATURE ALARM

In this point the thresholds above which the temperature alarm ($E 10$) is activated can be configured.
Note: The alarm must be enabled ("5.21.- ENABLING ALARMS").



Press the  key to enter edit mode. It is identified by the  symbol and the flashing of the digits to be modified.

The parameters to be configured are:

- ✓ The $L0$ value: when the device exceeds this value for 30 minutes, alarm $E09$ is triggered, and if alarm $E 11$ is enabled, the **Computer SMART III** device enters the **No Connection** status and activates alarm $E 11$.
- ✓ The $H1$ value: if the device exceeds this value for 30 seconds, alarm $E09$ is triggered, and if alarm $E 12$ is enabled, the **Computer SMART III** device enters the **Disconnection** status and activates alarm $E 12$.



If the device falls back under the $L0$ value during 10 minutes, it deactivates the alarms and returns to the normal operating status.

In the **No Connection** status, the device does not connect the stages, but also does not disconnect them if the operation requires it.

In the **Disconnection** status, it disconnects all the stages and does not allow them to connect.

The  key increases the digit value.

The  key reduces the digit value.

The  key skips to the previous digit and the  key skips to the next digit.

Press  to validate the data; the  symbol disappears from the display.

$L0$ Value and $H1$ Value:

Maximum value: 80°C.

Minimum value: 0°C

If the value entered is lower than the minimum value or higher than the maximum value, the backlight of the display flashes and the value entered is replaced with the minimum or maximum value, or with the last value validated.

Press the  key to access the next programming step.

If no keys are pressed for 5 minutes, the device switches to the simulation screen, "5.30.- SIMULATION SCREEN".

5.28.- LEAKAGE CURRENT ALARM

In this point the parameters of the leakage current alarm can be configured. Four alarms are linked to the leakage current (E 13, E 14, E 15 and E 16).

Note: The alarm must be enabled ("5.21.- ENABLING ALARMS").



Press the  key to enter edit mode. It is identified by the **EDIT** symbol and the flashing of the digits to be modified.

The parameters to be configured are:

- ✓ The **alarm value**: when the device exceeds this value, alarm E 13 is triggered.
- ✓ **Search for the responsible stage**: if this parameter is programmed as **On**, the device performs a process of connecting and disconnecting all the stages in order to find which ones are responsible for the leakage and, once they have been detected, cancels them so that they cannot connect again. The device triggers alarms E 13 and E 15 and the disabled stages are intermittently displayed on the screen.
- ✓ **Enable stages**: in this parameter, the stages that were disabled by this alarm are enabled again (**YES** option).

The  key increases the digit value and the next option.

The  key reduces the digit value and the previous option.

The  key skips to the previous digit and the  key skips to the next digit.

Press  to validate the data; the **EDIT** symbol disappears from the display.

Maximum value: 999 mA.

Minimum value: 1 mA.

If the value entered is lower than the minimum value or higher than the maximum value, the backlight of the display flashes and the value entered is replaced with the minimum or maximum value, or with the last value validated.

Press the  key to access the next programming step.

If no keys are pressed for 5 minutes, the device switches to the simulation screen, "5.30.- SIMULATION SCREEN".

5.29.- NO. OF OPERATIONS ALARM

In this point the number of operations of any of the stages above which the alarm *E 17* will be triggered can be configured.

Note: The alarm must be enabled ("5.21.- ENABLING ALARMS").



Press the  key to enter edit mode. It is identified by the **EDIT** symbol and the flashing of the digits to be modified.

The  key increases the digit value.

The  key reduces the digit value.

The  key skips to the previous digit and the  key skips to the next digit.

Press  to validate the data; the **EDIT** symbol disappears from the display.

Maximum value: 99999.

Minimum value: 10.

If the value entered is lower than the minimum value or higher than the maximum value, the backlight of the display flashes and the value entered is replaced with the minimum or maximum value, or with the last value validated.

Press the  key to access the next programming step.

If no keys are pressed for 5 minutes, the device switches to the simulation screen, "5.30.- SIMULATION SCREEN".

5.30.- SIMULATION SCREEN

This screen can be accessed by pressing the  key for more than 3 seconds, in order to exit the configuration status. This is an informative, non-editable screen.



The simulation screen provides certain information, which can be used to decide to enter the measurement **RUN** status when pressing the  key during 3 seconds or if no keys are pressed during 5 minutes, or to return to the configuration screens when pressing any of the other keys.

The screen shows the following information:

- ✓ Measurement of the $\cos \varphi$.
- ✓ Three-phase reactive power.
- ✓ The word *STOP*, as a reminder that the device is still not in the measurement status.
- ✓ Simulation of the steps that would be connected upon entering the measurement status and of the analogue bar.

6.- TECHNICAL FEATURES

AC power supply			
Rated voltage	Computer SMART III 6	Computer SMART III 12	Computer SMART III 14
	100 ... 520 V ~	100 ... 520 V ~	100 ... 400 V ~
Frequency	50 ... 60 Hz		
Consumption maximum	Computer SMART III 6	Computer SMART III 12	Computer SMART III 14
	10 ... 16 VA	13 ... 20 VA	14 ... 18 VA
Installation category	CAT III 300 V		
Voltage measurement circuit			
Rated voltage (Un)	230 V Ph-N, 400 V Ph-Ph		
Voltage measurement margin	20 ... 300 V Ph-N, 35 ... 520 V Ph-Ph		
Frequency measurement margin	45 ... 65 Hz		
Input impedance	660 kΩ		
Minimum measurement voltage (Vstart)	20 V Ph-N, 35 V Ph-Ph		
Installation category	CAT III 300 V		
Current measurement circuit			
Nominal current (In)	.../5 A or .../1 A		
Current measurement margin	1 ...120 % In		
Minimum measurement current (Istart)	50 mA		
Leakage current measurement circuit			
By means of an earth leakage transformer with a ratio of 500 turns			
Nominal current of the secondary	3 mA		
Current measurement margin	10 mA ... 1.5 A		
Minimum measurement current (Istart)	10 mA		
Measurement accuracy (UNE-EN 61557-12)			
Voltage measurement	0.5 % ± 1 digit		
Current measurement	0.5 % ± 1 digit		
Active power measurement	0.5% ± 2 digits		
Reactive power measurement	1% ± 2 digits		
Active energy measurement	Class 1		
Reactive energy measurement	Class 2		
Pulse outputs			
Quantity	2		
Type	NPN		
Maximum voltage	24 V $\overline{=}$		
Maximum current	50 mA		
Relay outputs			
Model	Computer SMART III 6	Computer SMART III 12	Computer SMART III 14
Quantity	8 (6 outputs, 1 fan, 1 alarm)	14 (12 outputs, 1 fan, 1 alarm)	16 (14 outputs, 1 fan, 1 alarm)
Maximum voltage, open contacts	1 kV		
Maximum current	1 A		
Maximum switching power	2500 VA		

Relay outputs (Continuation)	
Electrical life	30x10 ³ cycles
Mechanical working life	5x10 ⁶ cycles
Digital inputs	
Quantity	2
Type	Potential-free contact
Insulation	optoisolated
User interface	
Display	Custom COG LCD
Keypad	Capacitive, 5 keys
LED	4 LEDs
Communications	
Field bus	RS-485
Communication protocol	Modbus RTU
Baud rate	9600 - 19200
Stop bits	1 - 2
Parity	none - even - odd
Environmental features	
Operating temperature	-10°C ... +55°C
Storage temperature	-20°C ... +70°C
Relative humidity (non-condensing)	5 ... 95 %
Maximum altitude	2000 m
Protection degree	IP31 Front panel: IP51
Mechanical features	
Dimensions (Figure 21)	144x144x78 mm
Weight	575 g
Enclosure	Self-extinguishing V0 plastic
Attachment	Panel

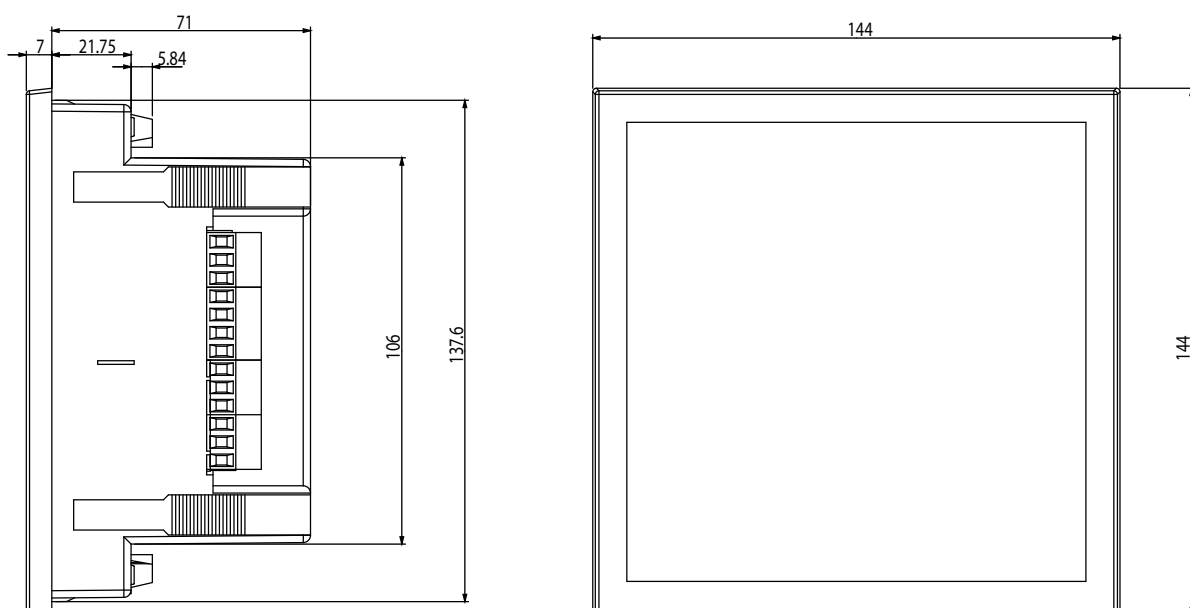

Figure 21: Dimensions of the Computer SMART III.

Standards	
Safety requirements for electrical equipment for measurement, control and laboratory use	UNE-EN 61010:2010
Electromagnetic compatibility (EMC) Part 6-2: Generic standards Immunity for industrial environments	UNE-EN 61000-6-2:2005
Electromagnetic compatibility (EMC) Part 6-4: Generic standards Emission standard for industrial environments	UNE-EN 61000-6-4:2005

7.- MAINTENANCE AND TECHNICAL SERVICE

In the case of any query in relation to device operation or malfunction, please contact the **CIRCUTOR SA** Technical Support Service.

Technical Assistance Service

Vial Sant Jordi, s/n, 08232 - Viladecavalls (Barcelona)

Tel: 902 449 459 (España) / +34 937 452 919 (outside of Spain)

email: sat@circutor.com

8.- WARRANTY

CIRCUTOR guarantees its products against any manufacturing defect for two years after the delivery of the units.

CIRCUTOR will repair or replace any defective factory product returned during the guarantee period.



- No returns will be accepted and no unit will be repaired or replaced if it is not accompanied by a report indicating the defect detected or the reason for the return.
- The guarantee will be void if the units has been improperly used or the storage, installation and maintenance instructions listed in this manual have not been followed. "Improper usage" is defined as any operating or storage condition contrary to the national electrical code or that surpasses the limits indicated in the technical and environmental features of this manual.
- **CIRCUTOR** accepts no liability due to the possible damage to the unit or other parts of the installation, nor will it cover any possible sanctions derived from a possible failure, improper installation or "improper usage" of the unit. Consequently, this guarantee does not apply to failures occurring in the following cases:
 - Overvoltages and/or electrical disturbances in the supply;
 - Water, if the product does not have the appropriate IP classification;
 - Poor ventilation and/or excessive temperatures;
 - Improper installation and/or lack of maintenance;
 - Buyer repairs or modifications without the manufacturer's authorisation.

9.- CE CERTIFICATE



DECLARACIÓN UE DE CONFORMIDAD

La presente declaración de conformidad se expide bajo la exclusiva responsabilidad de CIRCUITOR con dirección en Vial Sant Jordi, s/n – 08232 Viladecavalls (Barcelona) España

Producto:

Reguladores energía reactiva trifásico, regulación, medida, control de fugas y comunicaciones

Serie:

Computer Smart III 6, Computer Smart III 12, Computer Smart III 14

Marca:

CIRCUITOR

El objeto de la declaración es conforme con la legislación de armonización pertinente en la UE, siempre que sea instalado, mantenido y usado en la aplicación para la que ha sido fabricado, de acuerdo con las normas de instalación aplicables y las instrucciones del fabricante

2014/35/UE: Low Voltage Directive 2014/30/UE: Electromagnetic Compatibility Directive
2011/65/UE: RoHS2 Directive

Está en conformidad con la(s) siguiente(s) norma(s) u otro(s) documento(s) normativos(s):

IEC 62053-23:2003 Ed 1.0 IEC 61326-1:2012 Ed 2.0
IEC 61010-1:2010+AMD1:2016 CSV Ed 3.0 IEC 60947-1:2007+AMD1:2010+AMD2:2014 CSV Ed 5.2

Año de marcado "CE":

2014



EU DECLARATION OF CONFORMITY

This declaration of conformity is issued under the sole responsibility of CIRCUITOR with registered address at Vial Sant Jordi, s/n – 08232 Viladecavalls (Barcelona) Spain

Product:

Power Factor regulators. Regulation, measurement and protection all in one

Series:

Computer Smart III 6, Computer Smart III 12, Computer Smart III 14

Brand:

CIRCUITOR

The object of the declaration is in conformity with the relevant EU harmonisation legislation, provided that it is installed, maintained and used for the application for which it was manufactured, in accordance with the applicable installation standards and the manufacturer's instructions

2014/35/UE: Low Voltage Directive 2014/30/UE: Electromagnetic Compatibility Directive
2011/65/UE: RoHS2 Directive

It is in conformity with the following standard(s) or other regulatory document(s):

IEC 62053-23:2003 Ed 1.0 IEC 61326-1:2012 Ed 2.0
IEC 61010-1:2010+AMD1:2016 CSV Ed 3.0 IEC 60947-1:2007+AMD1:2010+AMD2:2014 CSV Ed 5.2

Year of CE mark:

2014



DECLARATION UE DE CONFORMITÉ

La présente déclaration de conformité est délivrée sous la responsabilité exclusive de CIRCUITOR dont l'adresse postale est Vial Sant Jordi, s/n – 08232 Viladecavalls (Barcelona) Espagne

Produit:

Régulateurs énergie réactive intelligents, mesure sur les 3 phases

Série:

Computer Smart III 6, Computer Smart III 12, Computer Smart III 14

Marque:

CIRCUITOR

L'objet de la déclaration est conforme à la législation d'harmonisation pertinente dans l'UE, à condition d'avoir été installé, entretenu et utilisé dans l'application pour laquelle il a été fabriqué, conformément aux normes d'installation applicables et aux instructions du fabricant

2014/35/UE: Low Voltage Directive 2014/30/UE: Electromagnetic Compatibility Directive
2011/65/UE: RoHS2 Directive

Il est en conformité avec la(les) suivante(s) norme(s) ou autre(s) document(s) réglementaire(s):

IEC 62053-23:2003 Ed 1.0 IEC 61326-1:2012 Ed 2.0
IEC 61010-1:2010+AMD1:2016 CSV Ed 3.0 IEC 60947-1:2007+AMD1:2010+AMD2:2014 CSV Ed 5.2

Année de marquage « CE »:

2014



Viladecavalls (Spain), 21/06/2017
General Manager: Ferran Gil Torné



CIRCUITOR, SA – Vial Sant Jordi, s/n
08232 Viladecavalls (Barcelona) Spain
(+34) 937 452 900 – info@circuitor.com



DECLARACIÓN CONFORMIDAD CE

Vorliegende Konformitätserklärung wird unter alleiniger Verantwortung von CIRCUITOR mit der Anschrift, Vial Sant Jordi, s/n – 08232 Viladecavalls (Barcelona) Spanien, ausgestellt

Producto:

Dreiphasen-Blindleistungsregler. Regulierung, Messung, Ableitstrom- und Kommunikationsüberwachung

Serie:

Computer Smart III 6, Computer Smart III 12, Computer Smart III 14

Marke:

CIRCUITOR

Der Gegenstand der Konformitätserklärung ist konform mit der geltenden Gesetzgebung zur Harmonisierung der EU, sofern die Installation, Wartung und Verwendung der Anwendung seinem Verwendungszweck entsprechend gemäß den geltenden Installationsstandards und der Vorgaben des Herstellers erfolgt.

2014/35/UE: Low Voltage Directive 2014/30/UE: Electromagnetic Compatibility Directive
2011/65/UE: RoHS2 Directive

Es besteht Konformität mit der/den folgenden Norm(Normen oder Regelwerk/Regelwerken

IEC 62053-23:2003 Ed 1.0 IEC 61326-1:2012 Ed 2.0
IEC 61010-1:2010+AMD1:2016 CSV Ed 3.0 IEC 60947-1:2007+AMD1:2010+AMD2:2014 CSV Ed 5.2

Jahr der CE-Kennzeichnung:

2014



DECLARAÇÃO DA UE DE CONFORMIDADE

A presente declaração de conformidade é expedida sob a exclusiva responsabilidade da CIRCUITOR com morada em Vial Sant Jordi, s/n – 08232 Viladecavalls (Barcelona) Espanha

Producto:

Reguladores de energia reactiva. Medida e compensação sobre as 3 fases da instalação

Série:

Computer Smart III 6, Computer Smart III 12, Computer Smart III 14

Marca:

CIRCUITOR

O objeto da declaração está conforme a legislação de harmonização pertinente na UE, sempre que seja instalado, mantido e utilizado na aplicação para a qual foi fabricado, de acordo com as normas de instalação aplicáveis e as instruções do fabricante.

2014/35/UE: Low Voltage Directive 2014/30/UE: Electromagnetic Compatibility Directive
2011/65/UE: RoHS2 Directive

Está em conformidade com a(s) seguinte(s) norma(s) ou outro(s) documento(s) normativo(s):

IEC 62053-23:2003 Ed 1.0 IEC 61326-1:2012 Ed 2.0
IEC 61010-1:2010+AMD1:2016 CSV Ed 3.0 IEC 60947-1:2007+AMD1:2010+AMD2:2014 CSV Ed 5.2

Ano de marcação "CE":

2014



DICHIARAZIONE DI CONFORMITÀ UE

La presente dichiarazione di conformità viene rilasciata sotto la responsabilità esclusiva di CIRCUITOR, con sede in Vial Sant Jordi, s/n – 08232 Viladecavalls (Barcelona) Spagna

prodotto:

Regolatori energia reattiva trifase. regolazione, misurazione, controllo di fughe e comunicazioni

Serie:

Computer Smart III 6, Computer Smart III 12, Computer Smart III 14

MARCHIO:

CIRCUITOR

L'oggetto della dichiarazione è conforme alla pertinente normativa di armonizzazione dell'Unione Europea, a condizione che venga installato, mantenuto e utilizzato nell'ambito dell'applicazione per cui è stato prodotto, secondo le norme di installazione applicabili e le istruzioni del produttore.

2014/35/UE: Low Voltage Directive 2014/30/UE: Electromagnetic Compatibility Directive
2011/65/UE: RoHS2 Directive

È conforme alle seguenti normative o altri documenti normativi:

IEC 62053-23:2003 Ed 1.0 IEC 61326-1:2012 Ed 2.0
IEC 61010-1:2010+AMD1:2016 CSV Ed 3.0 IEC 60947-1:2007+AMD1:2010+AMD2:2014 CSV Ed 5.2

Anno di marcatura "CE":

2014



Viladecavalls (Spain), 21/06/2017
General Manager: Ferran Gil Torné



CIRCUTOR, SA – Vial Sant Jordi, s/n
08232 Viladecavalls (Barcelona) Spain
(+34) 937 452 900 – info@circutor.com



DEKLARACJA ZGODNOŚCI UE

Niniejsza deklaracja zgodności została wydana na wyłączną odpowiedzialność firmy CIRCUTOR z siedzibą pod adresem: Vial Sant Jordi, s/n – 08232 Viladecavalls (Barcelona) Hiszpania

produkt:

Regulator mocy biernej; regulacja, pomiar i ochrona w jednym

Seria:

Computer Smart III 6, Computer Smart III 12, Computer Smart III 14

marka:

CIRCUTOR

Przedmiot deklaracji jest zgodny z odnoszonymi wymaganiami prawodawstwa harmonizacyjnego w Unii Europejskiej pod warunkiem, że będzie instalowany, konserwowany i użytkowany zgodnie z przeznaczeniem, dla którego został wyprodukowany, zgodnie z mającymi zastosowanie normami dotyczącymi instalacji oraz instrukcjami producenta

2014/35/UE: Low Voltage Directive 2014/30/UE: Electromagnetic Compatibility Directive

2011/65/UE: RoHS2 Directive

Jest zgodny z następującą(y) normą(ami) lub innymi(i) dokumentem(ami) normatywnym(i):

IEC 62053-23:2003 Ed 1.0 IEC 61326-1:2012 Ed 2.0
IEC 61010-1:2010+AMD1:2016 CSV Ed 3.0 IEC 60947-4:2007+AMD1:2010+AMD2:2014 CSV Ed 5.2

Rok oznakowania "CE":

2014

Viladecavalls (Spain), 21/06/2017
General Manager: Ferran Gil Torné



CIRCUTOR, SA

Vial Sant Jordi, s/n

08232 -Viladecavalls (Barcelona)

Tel.: (+34) 93 745 29 00 - Fax: (+34) 93 745 29 14

www.circutor.com central@circutor.com