



RZ-15-400-14%

RZ-15-400-14%, Reactors III for detuned filters

Code: P731200000300

- > L(mH): 5,43
- > For capacitor: CLZ-FP-52/25-HD | CFB-52/23
- > In (A): 22
- > Frequency (Hz): 50
- > kvar (400 V): 15
- > Losses: 130
- > Un (V): 400

Description

CIRCUTOR has a complete range of detuned reactors, $p = 7\%$, with a resonance frequency of 189 Hz for 50 Hz networks (or, on demand, 227 Hz for 60 Hz networks). This is the most frequent tuning value to avoid any resonance with the 5th harmonic and over. The set of capacitors-reactors absorbs part of the current of the 5th harmonic and acts as a detuned filter for higher frequencies. In some installations, anyway, other value of $p(\%)$ can be required, for example, 8,7 % (170 Hz), 14 % (134 Hz).... **CIRCUTOR** can manufacture reactors adapted to any power, $p(\%)$, frequency, voltage ($Un \leq 1000$ VAC).

Reactors for low power rating, **RZ** range, are built with low losses magnetic sheets and coiled with aluminum wires. A terminal block for the connection of the reactor is fitted. Higher powers are covered by RBH range. These reactors are based on a magnetic sheet core with multiple air gaps, which provides them with excellent characteristics and low loss ratios.

Both **RZ** and **RBZ** reactors are subjected to a varnish vacuum impregnation, based on polyester resin, to increase the insulation, providing a greater mechanical resistance and reducing the level of noise.

Application

RZ and **RBZ** detuned reactors have been specially designed for their use in installations with capacitor banks with considerably high harmonic distortion rates. The reactors must be connected in series to the proper power capacitor for the satisfactory protection of the own capacitors and to avoid the resonance effects in the installation.



RZ-15-400-14%

Reactors

Code: P731200000300

Specifications

AC power supply

Frequency	50 Hz
-----------	-------

Electrical characteristic

Overvoltage factor (p %)	14 % (134 Hz)
--------------------------	---------------

Mechanical characteristics

Size (mm) width x height x depth	250 x 245 x 145 (mm)
Envelope	Conductor type: Aluminium strip / copper cable
Weight (kg)	20

Environmental characteristics

Thermal Class	class F (+155 °C) On request: class H (+180 °C)
Protection class	IP 00
Ambient temperature	-10 ... +45 °C

Electrical characteristics

Linearity (5% L)	1,75 x I _n
Maximum transient current	2 I _n (1 min)
Voltage	400 V, on request: up to 1000 V
Tolerance L	± 5 %
L value (mH)	5.43
Insulation voltage, circuit	3 kV

Current measurement circuit

Allowable overload	1,17 x I _n
Permanent overload	1,17 x I _n

Standards

Standards	UNE-EN 60289, IEC 60076
-----------	-------------------------

Protection

Circuit breaker type	9125°C NC thermostat
----------------------	----------------------

RZ-RBZ

Reactors III for detuned filters



RZ-15-400-14%

Reactors

Code: P731200000300

CODE	TYPE	L(mH)	For capacitor	In (A)	Frequency (Hz)	kvar (400 V)	Losses	Un (V)	P%
400 Vac, 50 Hz, f resonance = 189 Hz / p= 7%									
P73110.	RZ-5-400	7,66	CLZ-FP-46/6,25	7,2	50	5	26	400	7%
P73112.	RZ-6,25-400	6,1	CLZ-FP-52/10	9	50	6,25	33	400	7%
P73115.	RZ-10-400	3,83	CLZ-FP-46/12,5	15	50	10	52	400	7%
P73117.	RZ-12,5-400	3,05	CLZ-FP-46/15	18	50	12,5	57	400	7%
P73120.	RZ-15-400	2,55	CLZ-FP-46/19	22	50	15	59	400	7%
P73125.	RBZ-20-400	1,91	CLZ-FP-46/25	29	50	20	79	400	7%
P73130.	RBZ-25-400	1,53	CLZ-FP-46/30	36	50	25	93	400	7%
P73135.	RBZ-30-400	1,27	2 x CLZ-FP-46/19	43	50	30	124	400	7%
P73140.	RBZ-40-400	0,95	2 x CLZ-FP-46/25	58	50	40	149	400	7%
P73145.	RBZ-50-400	0,76	2 x CLZ-FP-46/30	72	50	50	189	400	7%
P73150.	RBZ-60-400	0,63	3 x CLZ-FP-46/25	87	50	60	210	400	7%
P73155.	RBZ-80-400	0,48	3 x CLZ-FP-46/33,3	115	50	80	241	400	7%
400 Vac, 50 Hz, f resonance = 134 Hz / p= 14%									
P731100000300	RZ-5-400-14%	16,31	CLZ-FP-52/7,5-HD CFB-52/7,5	7,2	50	5	62	400	14%
P731150000300	RZ-10-400-14%	8,15	CLZ-FP-52/15-HD CFB-52/15	15	50	10	91	400	14%
P731170000300	RZ-12,5-400-14%	6,52	CLZ-FP-52/20-HD CFB-52/19	18	50	12,5	130	400	14%
P731200000300	RZ-15-400-14%	5,43	CLZ-FP-52/25-HD CFB-52/23	22	50	15	130	400	14%
P731250000300	RZ-20-400-14%	4,07	CLZ-FP-52/30-HD CFB-52/30	29	50	20	150	400	14%
P731300000300	RBZ-25-400-14%	3,26	CLZ-FP-52/12,5-HD + CLZ-FP-52/30-HD CFB-52/38	36	50	25	168	400	14%
P731350000300	RBZ-30-400-14%	2,71	CLZ-FP-52/25-HD + CLZ-FP-52/20-HD CFB-52/46	43	50	30	191	400	14%
P731400000300	RBZ-40-400-14%	2,03	2 x CLZ-FP-52/30-HD CFB-52/60,5	58	50	40	267	400	14%
P731450000300	RBZ-50-400-14%	1,63	3 x CLZ-FP-52/25-HD CFB-52/76	72	50	50	341	400	14%
P731500000300	RBZ-60-400-14%	1,35	3 x CLZ-FP-52/30-HD CFB-52/91	87	50	60	421	400	14%



RZ-15-400-14%

Reactors

Code: P731200000300

Dimensions

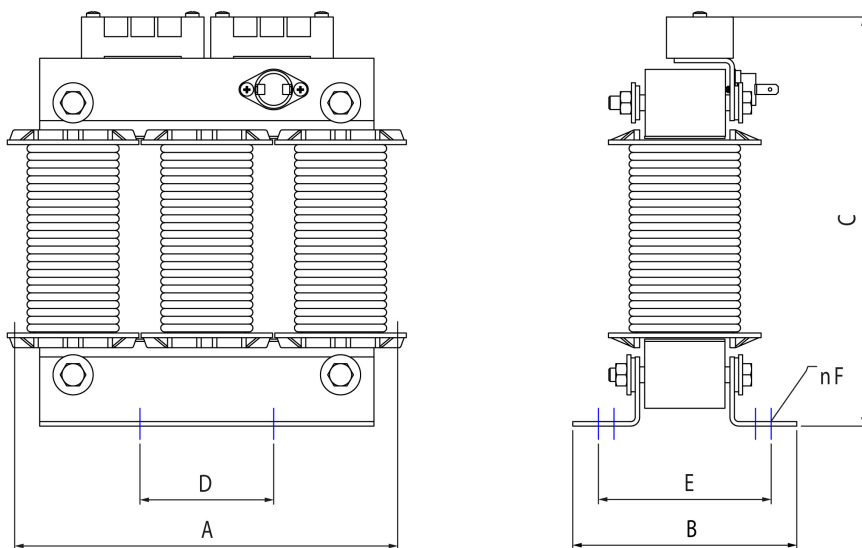

Tipo	A mm	B mm	C mm	D* mm	E* mm	F mm	G mm	kg
RZ-5-400	155	76	165	75	55	7	-	4
RZ-6,24-400	180	112	190	90	75	7	-	6
RZ-10-400	180	112	190	90	75	7	-	6,5
RZ-12,5-400	180	112	190	90	75	7	-	7
RZ-15-400	180	112	190	90	75	7	-	8

Tipo	A mm	B mm	C mm	D* mm	E* mm	F mm	G mm	kg
REZ-05-400	150	90	155	75	70	7	-	4
REZ-10-400	180	110	195	90	83	7	-	7
REZ-15-400	180	120	195	90	93	7	-	9
REZ-20-400	250	130	245	130	98	7	-	15
REZ-25-400	250	130	245	130	98	7	-	16
REZ-30-400	250	130	245	130	98	7	-	17

* Distance between fixations